



DATA IMAGE CORPORATION

TFT Module Specification

Preliminary

ITEM NO.: FG080074DSSWBGL2

Table of Contents

- 1. COVER & CONTENTS 1
- 2. RECORD OF REVISION 2
- 3. GENERAL SPECIFICATIONS 3
- 4. ABSOLUTE MAXIMUM RATINGS 3
- 5. ELECTRICAL CHARACTERISTICS 3
- 6. TIMING CHARACTERISTICS..... 4
- 7. OPTICAL CHARATERISTIC 8
- 8. PIN CONNECTIONS 11
- 9. BLOCK DIAGRAM 12
- 10. QUALITY ASSURANCE 13
- 11. LCM PRODUCT LABEL DEFINE 17
- 12. PRECAUTIONS IN USE LCM 19
- 13. OUTLINE DRAWING 20
- 14. PACKAGE INFORMATION..... 21

Customer Companies	R&D Dept.	Q.C. Dept.	Eng. Dept.	Prod. Dept.
	ALEX	JOE	GARY	KEN
Approved by	Version:	Issued Date:	Sheet Code:	Total Pages:
	1	29/SEP14'		21

3. GENERAL SPECIFICATIONS

Parameter	Specifications	Unit
Screen Size	8 (diagonal)	inch
Display Format	800(H) x (R,G,B) x 600(V)	dot
Active Area	162(H) x 121.5 (V)	mm
Dot Pitch	0.0675 (H) x 0.2025 (V)	mm
Pixel Configuration	R.G.B.-Stripe	
Outline Dimension	183(W) x 141(H) x 8.8Max(D)	mm
Surface treatment	Anti-glare	
Back-light	LED	
Display mode	Normally white	
Weight	TBD	g
View Angle direction	6 o'clock	
Our components and processes are compliant to RoHS standard		

4. ABSOLUTE MAXIMUM RATINGS

GND= 0V

Parameter	Symbol	MIN.	MAX.	Unit	Remark
Power supply voltage	VCC	-0.3	4.0	V	Ta=25°C
Logic input voltage	VI	-0.3	VCC+0.3	V	
Operating temperature	Top	-20	70	°C	
Storage temperature	Tst	-30	80	°C	

5. ELECTRICAL CHARACTERISTICS

Module

Parameter	Symbol	MIN.	Typ.	MAX.	Unit	Remark
Power Supply voltage	VCC	3.0	3.3	3.6	V	
Power Supply Current	I _{CC}	--	200	300	mA	VCC =3.3V
Differential Input High Threshold	V _{TH}	-	-	100	[mV]	V _{CM} =1.2V Note 1
Differential Input Low Threshold	V _{TL}	-100	-	-	[mV]	
Ripple voltage	V _{RF}	-	-	100	mV _{P-P}	

Note 1: LVDS Signal Waveform.

Differential Signal

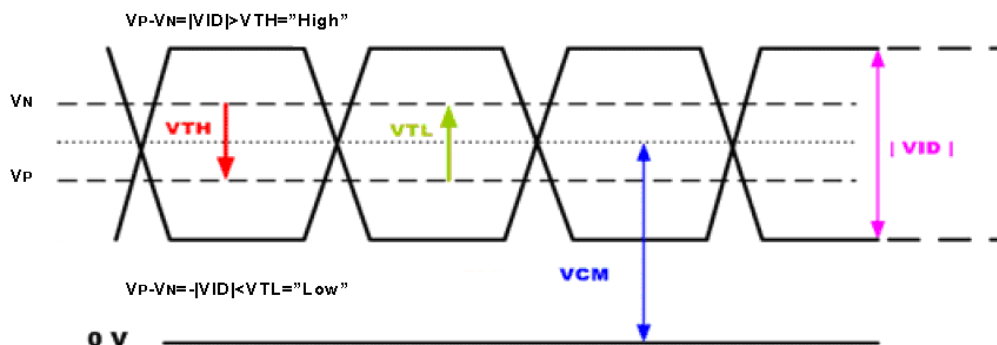

Backlight Driving Conditions

Ta= 25 °C

Parameter	Symbol	Min.	Typ.	Max.	Unit	Remark
VLED voltage	V_L	21	-	24.5	V	Note 1
LED current	IF	--	120	--	mA	
LED Life Time decay to 50%		30,000	50,000	--	hr	Note 2

Note 1: The LED Supply Voltage is defined by the number of LED at Ta=25°C and IF =120mA.

Note 2: The "LED life time" is defined as the module brightness decrease to 50% original brightness at Ta=25°C and IF =120mA. The LED lifetime could be decreased if operating IL is larger than 120mA.

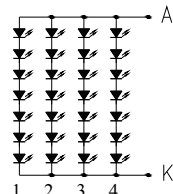

LED circuit

VF:21V~24.5V(MAX)

IF:120mA(Fix)

6. Timing Characteristics

6.1 Input signal characteristics

6.1.1 AC Electrical Characteristics

Parameter	Symbol	MIN.	TYP.	MAX.	Unit
Data setup time	T_{dsu}	8	-	-	ns
Data hold time	T_{dhd}	8	-	-	ns
DEN setup time	T_{esu}	8	-	-	ns

6.1.2 Resolution : 800x600

Parameter	Symbol	MIN.	TYP.	MAX.	Unit
DCLK frequency	F_{CPH}	-	40	50	MHz
DCLK period	T_{CPH}	20	25	-	ns
DCLK pulse duty	T_{CWH}	40	50	60	%
DE period	$T_{DEH}+T_{DEL}$	862	1056	1200	T_{CPH}
DE pulse width	T_{DH}	-	800	-	T_{CPH}
DE frame blanking	T_{DEB}	24	35	100	$T_{DEH}+T_{DEL}$
DE frame width	T_{DE}	-	600	-	$T_{DEH}+T_{DEL}$

6.2 Timing Controller Timing Chart

6.2.1 Clock and Data input waveforms

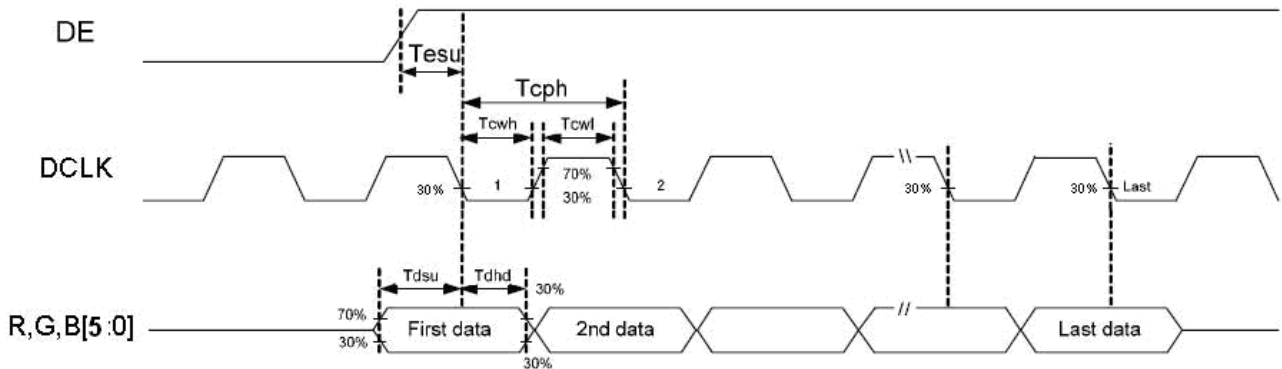
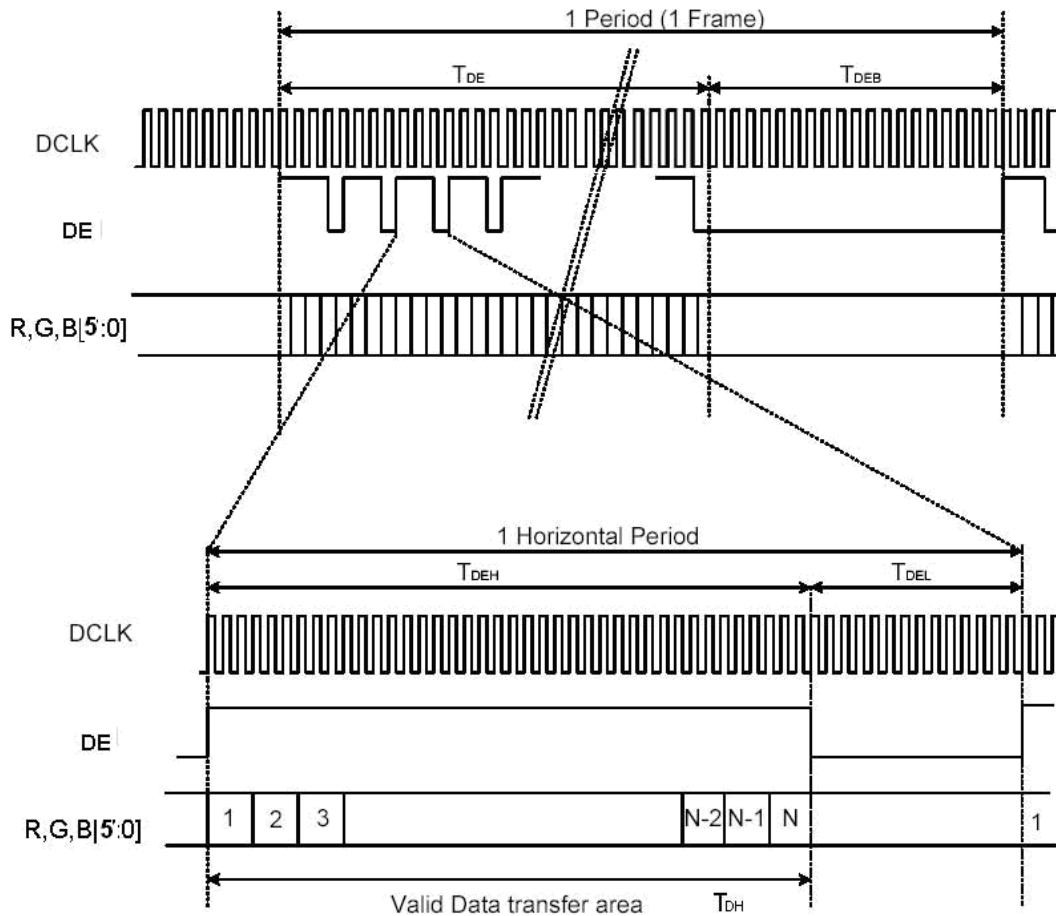

Figure 1 Clock and Data input waveforms.



N=800

Figure 2 DE Mode Data Format

6.2.2 LVDS Timing Chart

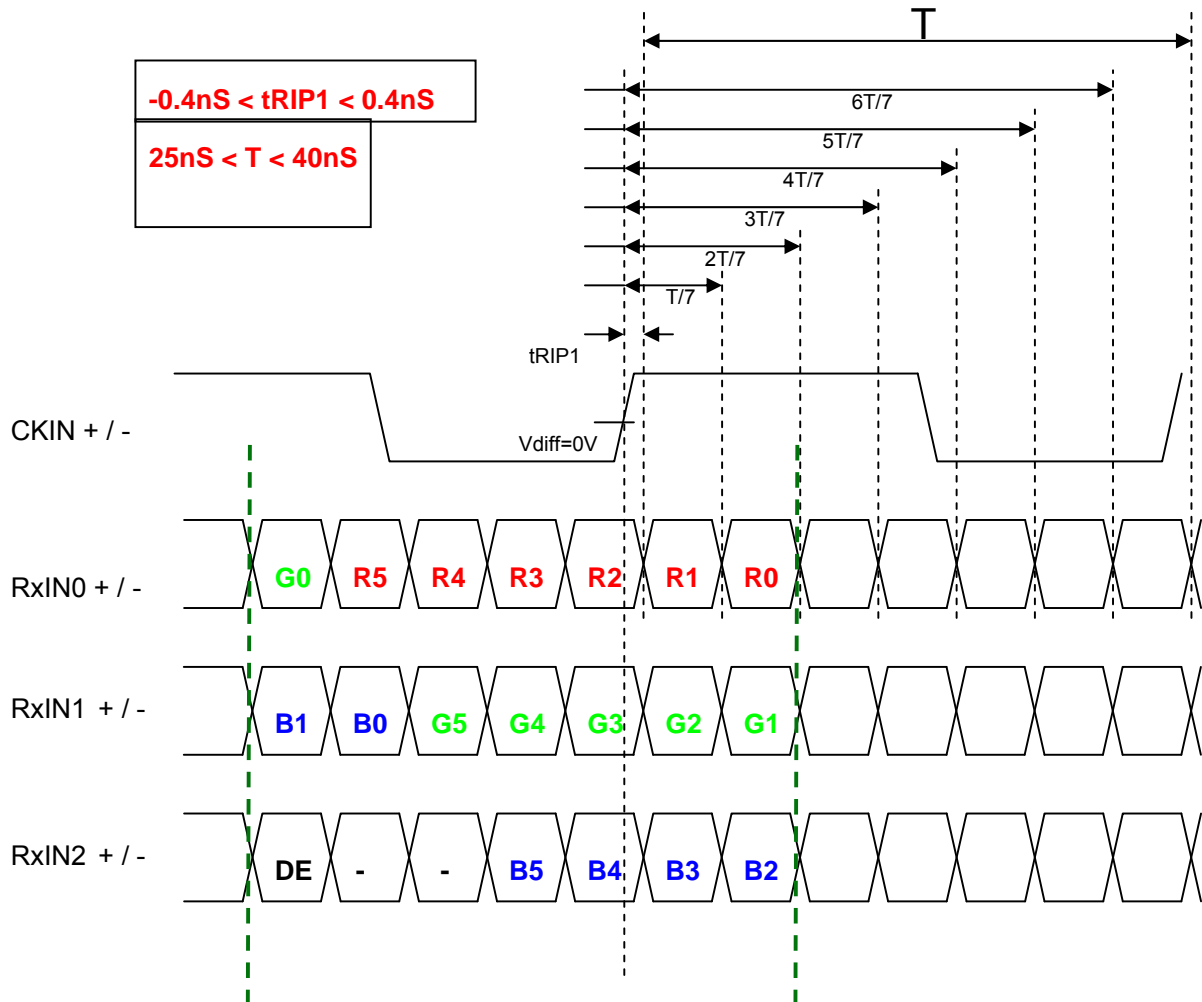

6.3 Color Data Input Assignment

		Data Signal																	
		Red						Green						Blue					
Color		R5	R4	R3	R2	R1	R0	G5	G4	G3	G2	G1	G0	B5	B4	B3	B2	B1	B0
Basic Colors	Black	0	0	0	0	0	0	0	0	0	0	0	0	0	0	0	0	0	0
	Red	1	1	1	1	1	1	0	0	0	0	0	0	0	0	0	0	0	0
	Green	0	0	0	0	0	0	1	1	1	1	1	1	0	0	0	0	0	0
	Blue	0	0	0	0	0	0	0	0	0	0	0	0	1	1	1	1	1	1
	Cyan	0	0	0	0	0	0	1	1	1	1	1	1	1	1	1	1	1	1
	Magenta	1	1	1	1	1	1	0	0	0	0	0	0	1	1	1	1	1	1
	Yellow	1	1	1	1	1	1	1	1	1	1	1	1	0	0	0	0	0	0
	White	1	1	1	1	1	1	1	1	1	1	1	1	1	1	1	1	1	1
Gray Scale of Red	Red(0) / Dark	0	0	0	0	0	0	0	0	0	0	0	0	0	0	0	0	0	0
	Red(1)	0	0	0	0	0	1	0	0	0	0	0	0	0	0	0	0	0	0
	Red(2)	0	0	0	0	1	0	0	0	0	0	0	0	0	0	0	0	0	0
	:	:	:	:	:	:	:	:	:	:	:	:	:	:	:	:	:	:	:
	:	:	:	:	:	:	:	:	:	:	:	:	:	:	:	:	:	:	:
	Red(61)	1	1	1	1	0	1	0	0	0	0	0	0	0	0	0	0	0	0
	Red(62)	1	1	1	1	1	0	0	0	0	0	0	0	0	0	0	0	0	0
	Red(63)	1	1	1	1	1	1	0	0	0	0	0	0	0	0	0	0	0	0
Gray Scale of Green	Green(0)/ Dark	0	0	0	0	0	0	0	0	0	0	0	0	0	0	0	0	0	0
	Green(1)	0	0	0	0	0	0	0	0	0	0	0	1	0	0	0	0	0	0
	Green(2)	0	0	0	0	0	0	0	0	0	0	1	0	0	0	0	0	0	0
	:	:	:	:	:	:	:	:	:	:	:	:	:	:	:	:	:	:	:
	:	:	:	:	:	:	:	:	:	:	:	:	:	:	:	:	:	:	:
	Green(61)	0	0	0	0	0	0	1	1	1	1	0	1	0	0	0	0	0	0
	Green(62)	0	0	0	0	0	0	1	1	1	1	1	0	0	0	0	0	0	0
	Green(63)	0	0	0	0	0	0	1	1	1	1	1	1	0	0	0	0	0	0
Gray Scale of Blue	Blue(0)/ Dark	0	0	0	0	0	0	0	0	0	0	0	0	0	0	0	0	0	0
	Blue (1)	0	0	0	0	0	0	0	0	0	0	0	0	0	0	0	0	0	1
	Blue (2)	0	0	0	0	0	0	0	0	0	0	0	0	0	0	0	0	1	0
	:	:	:	:	:	:	:	:	:	:	:	:	:	:	:	:	:	:	:
	:	:	:	:	:	:	:	:	:	:	:	:	:	:	:	:	:	:	:
	Blue (61)	0	0	0	0	0	0	0	0	0	0	0	0	1	1	1	1	0	1
	Blue (62)	0	0	0	0	0	0	0	0	0	0	0	0	1	1	1	1	1	0
	Blue (63)	0	0	0	0	0	0	0	0	0	0	0	0	1	1	1	1	1	1

6.4 Pixel Format Image

Following figure shows the relationship of the input signals and LCD pixel format :

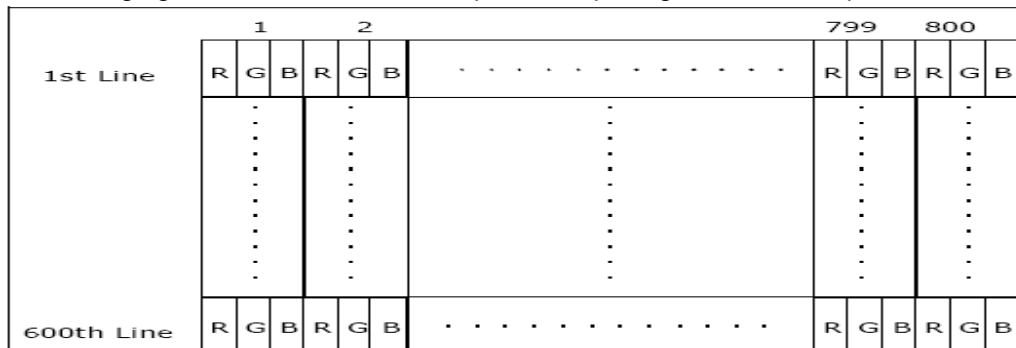

7. OPTICAL CHARACTERISTIC

Parameter	Symbol	Condition	MIN.	TYP.	MAX.	Unit	Remarks	
Viewing Angle	Horizontal	θ_{x+}	60	70	--	deg	Note 1,4	
		θ_{x-}	60	70	--			
	Vertical	θ_{y+}	CR \geq 10	40	50			--
		θ_{y-}		60	70			--
Contrast Ratio	CR max.	Center	400	500	--		Note 1,3	
Response time	Rise	Tr	-	10	20	ms	Note 1,6	
	Fall	Tf	$\theta_x=\theta_y=0^\circ$	-	15	30		ms
Brightness Uniformity	B-uni	$\theta_x=\theta_y=0^\circ$	70	75	--	%	Note 1,5	
Central Luminance	L	IL=mA	400	500	--	cd/m ²	Note 1,2	
White Chromaticity	x_w	Center	0.26	0.31	0.36		Note 1,2	
	y_w	$\theta_x=\theta_y=0^\circ$	0.28	0.33	0.38			
Image sticking	tis	2 hours			2	Sec	Note 7	

The following optical specifications shall be measured in a darkroom or equivalent state (ambient luminance ≤ 1 lux, and at room temperature). The operation temperature is $25^\circ\text{C} \pm 2^\circ\text{C}$, and LED current $I_F=120\text{mA}$. The measurement method is shown in Note 1.

Note 1: The method of optical measurement:

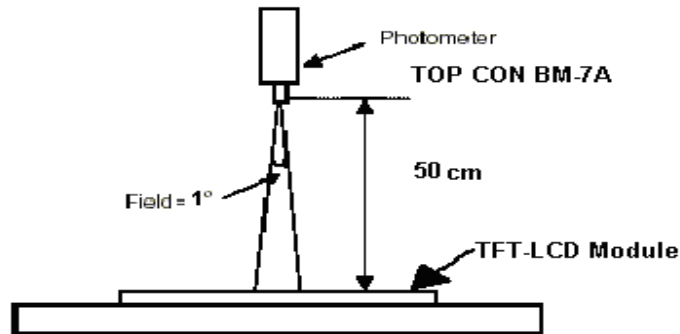

Note 2: Measured at the central point of the LCD module and at the viewing angle of the $\theta_x=\theta_y=0^\circ$

Note 3: Definition of Contrast Ratio (CR):

$$CR = \frac{\text{Luminance with all pixels in white state}}{\text{Luminance with all pixels in Black state}}$$

Note 4: Definition of Viewing Angle(CR≥10):

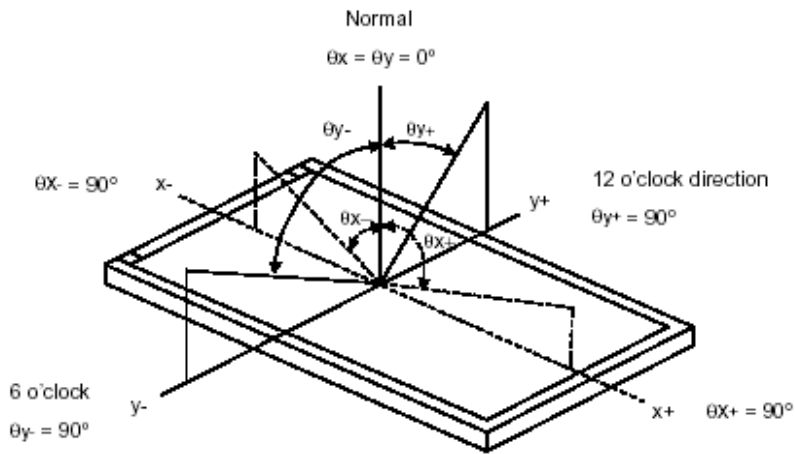

Note 5: Definition of Brightness Uniformity (B-uni):

Luminance Measuring Points

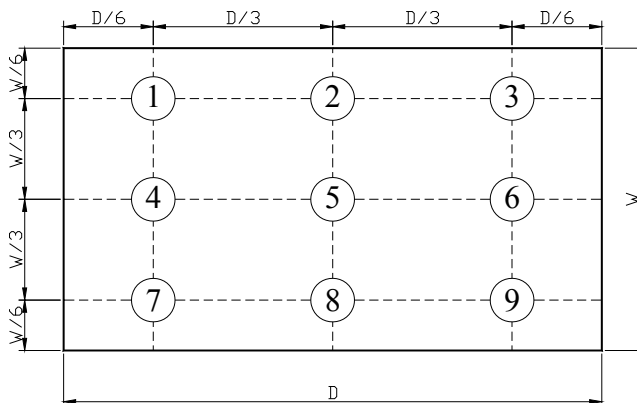

$$B\text{-uni} = \frac{\text{Minimum luminance of 9 points}}{\text{Maximum luminance of 9 points}}$$

Note6: Definition of Response Time:

The Response Time is set initially by defining the "Rising Time (Tr)" and the "Falling Time (Tf)" respectively. Tr and Tf are defined as following figure.

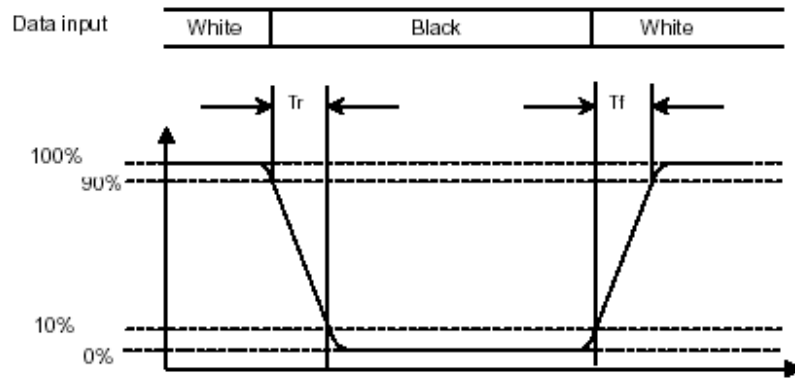

Note 7: Definition of Image sticking (tis):

Continuously display the test pattern shown in the figure below for 2 hours. Then display a completely white screen. The previous image shall not persist more than 2 sec at 25 °C

Image sticking pattern

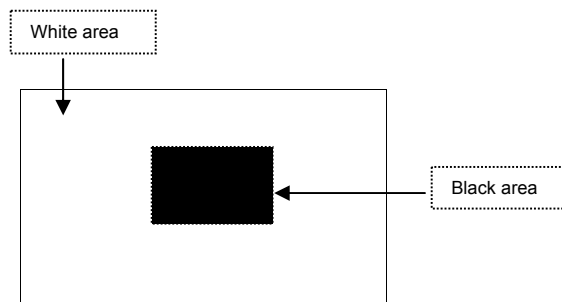

8. PIN CONNECTIONS

8.1 TFT LCD Panel Driving Section

Pin	Name	Description	Remark
1	VCC	Power Supply	
2	VCC	Power Supply	
3	GND	Ground	
4	GND	Ground	
5	RXIN0-	Differential Data Input, CH0 (Negative)	R0 ~ R5, G0
6	RXIN0+	Differential Data Input, CH0 (Positive)	
7	GND	Ground	
8	RXIN 1-	Differential Data Input, CH1 (Negative)	G1 ~ G5, B0, B1
9	RXIN 1+	Differential Data Input , CH1 (Positive)	
10	GND	Ground	
11	RXIN 2-	Differential Data Input , CH2 (Negative)	B2 ~ B5, NC, NC,DE
12	RXIN 2+	Differential Data Input , CH2 (Positive)	
13	GND	Ground	
14	CKIN-	Differential Clock Input (Negative)	DCLK
15	CKIN+	Differential Clock Input (Positive)	
16	GND	Ground	
17	NC	No connection	
18	NC	No connection	
19	GND	Ground	
20	GND	Ground	

8.2 Power Signal Sequence

$t1 \leq 10\text{ms}$: $1 \text{ sec} \leq t5$
 $50\text{ms} \leq t2$: $200\text{ms} \leq t6$
 $0 < t3 \leq 50\text{ms}$: $200\text{ms} \leq t7$
 $0 < t4 \leq 10\text{ms}$

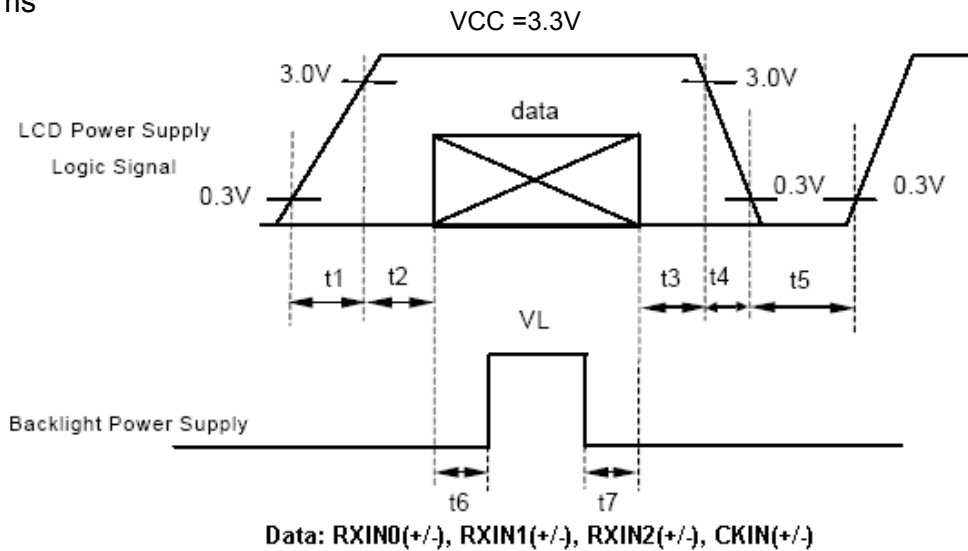

9. BLOCK DIAGRAM

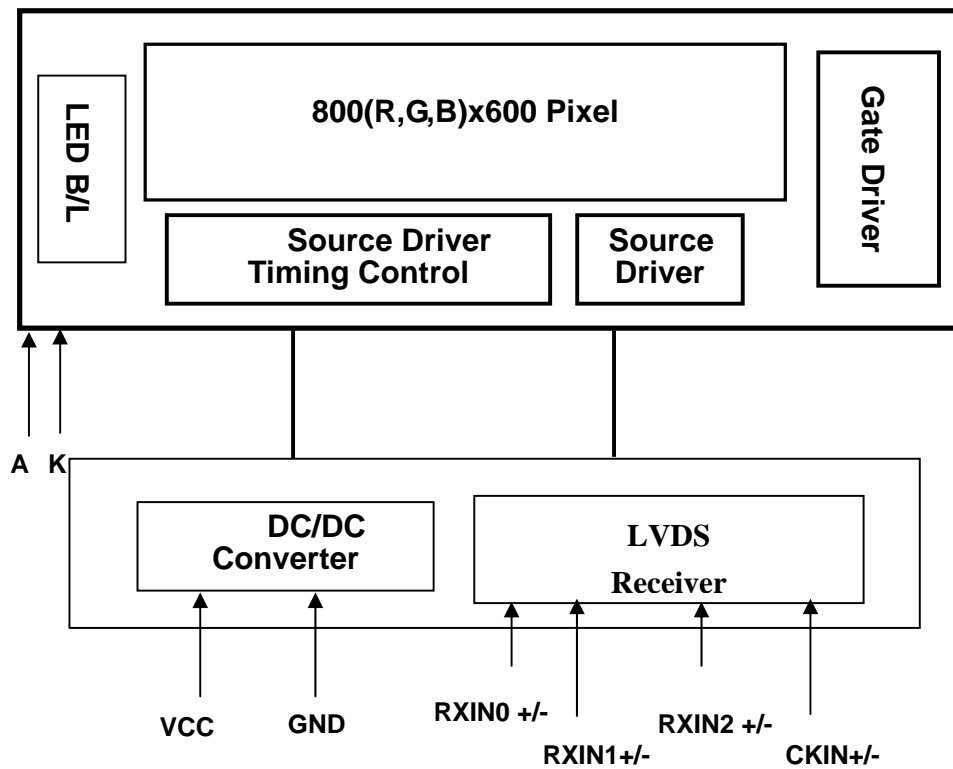

10. QUALITY ASSURANCE

10.1 Test Condition

10.1.1 Temperature and Humidity(Ambient Temperature)

Temperature : $25 \pm 5^{\circ}\text{C}$

Humidity : $65 \pm 5\%$

10.1.2 Operation

Unless specified otherwise, test will be conducted under function state.

10.1.3 Container

Unless specified otherwise, vibration test will be conducted to the product itself without putting it in a container.

10.1.4 Test Frequency

In case of related to deterioration such as shock test. It will be conducted only once.

10.1.5 Test Method

Reliability Test Item & Level		Test Level	Remark
No.	Test Item		
1	High Temperature Storage Test	T= 80°C ,240hrs	IEC68-2-2
2	Low Temperature Storage Test	T= -30°C ,240hrs	IEC68-2-1
3	High Temperature Operation Test	T= 70°C ,240hrs	IEC68-2-2
4	Low Temperature Operation Test	T= -20°C ,240hrs	IEC68-2-1
5	High Temperature and High Humidity Operation Test	T= 60°C ,90%RH,240hrs	IEC68-2-3
6	Thermal Cycling Test (No operation)	$-30^{\circ}\text{C} \rightarrow +25^{\circ}\text{C} \rightarrow +80^{\circ}\text{C}$,100 Cycles 30 min 5 min 30 min	IEC68-2-14
7	Vibration Test (No operation)	Frequency : 10 ~ 55 Hz Amplitude : 1.5 mm Sweep Time : 11mins Test Period : 6 Cycles for each Direction of X,Y,Z	IEC68-2-6
8	Shock Test (No operation)	100G, 6ms Direction : $\pm X, \pm Y, \pm Z$ Cycle : 3 times	IEC68-2-27

10.2 Inspection condition

10.2.1 Inspection conditions

10.2.1.1 Inspection Distance : 35 ± 5 cm

10.2.1.2 View Angle :

(1) Inspection under operating condition : $\pm 5^\circ$

(2) Inspection under non-operating condition : $\pm 45^\circ$

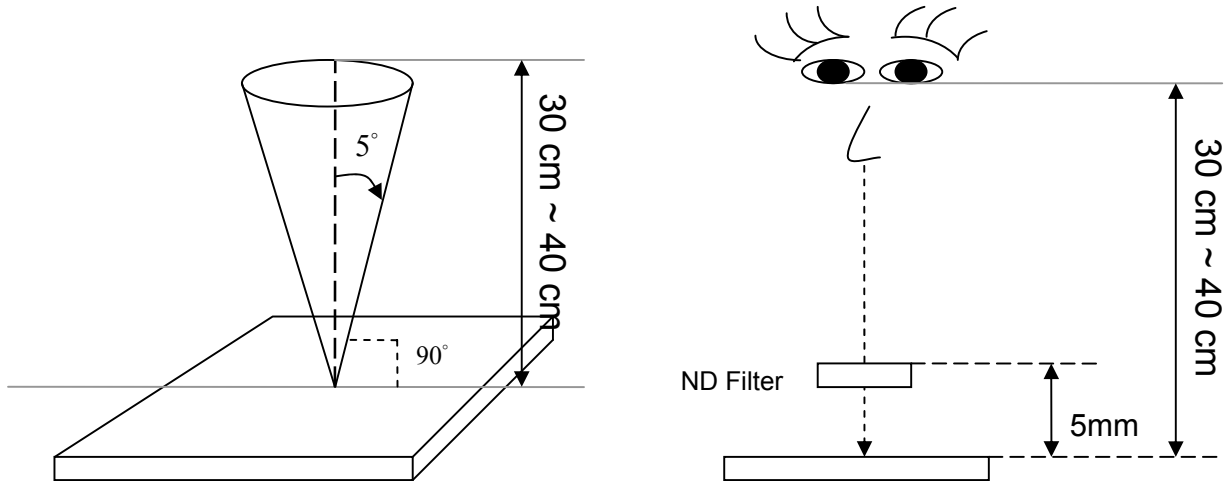

10.2.2 Environment conditions :

Ambient Temperature :		$25 \pm 5^\circ\text{C}$
Ambient Humidity :		$65 \pm 5\%$
Ambient Illumination	Cosmetic Inspection	More than 600lux
	Functional Inspection	300 ~ 800lux

10.2.3 Definition of applicable Zones

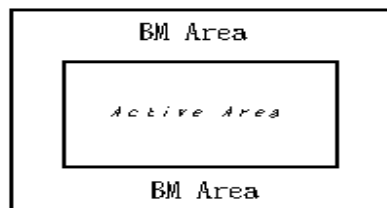

10.2.4 Inspection Parameters

No.	Parameter	Criteria																		
1	Operating	Display function: No Display malfunction (Major)																		
		Contrast ratio (Black, White): Does not meet specified range in the spec. (Major) (Note:3)																		
		Line Defect: No obvious Vertical and Horizontal line defect in bright, dark and colored. (Major) (Note:1)																		
		Point Defect (Red, green, blue, dark): Active area ≤ 5 dots (Minor)(Note:1)																		
		<table border="1"> <thead> <tr> <th>Item</th> <th>Acceptable number</th> <th>Total</th> <th>Class Of Defects</th> <th>AQL Level</th> </tr> </thead> <tbody> <tr> <td>Bright</td> <td>4</td> <td rowspan="2">8</td> <td rowspan="4">Minor</td> <td rowspan="4">1.5</td> </tr> <tr> <td>Dark</td> <td>4</td> </tr> <tr> <td>Adjacent Bright</td> <td>1</td> <td>1</td> </tr> <tr> <td>Adjacent Dark</td> <td>1</td> <td>1</td> </tr> </tbody> </table>	Item	Acceptable number	Total	Class Of Defects	AQL Level	Bright	4	8	Minor	1.5	Dark	4	Adjacent Bright	1	1	Adjacent Dark	1	1
		Item	Acceptable number	Total	Class Of Defects	AQL Level														
		Bright	4	8	Minor	1.5														
		Dark	4																	
		Adjacent Bright	1	1																
		Adjacent Dark	1	1																
		Non-uniformity: Visible through 2%ND filter white, R, G, B and gray 50%pattern. (Minor)																		
Foreign material in Black or White spots shape ($W > 1/4L$) (Note: 5)																				
<table border="1"> <thead> <tr> <th>Dimension</th> <th>Acceptable number</th> <th>Class Of Defects</th> <th>AQL Level</th> </tr> </thead> <tbody> <tr> <td>$D \leq 0.3$</td> <td>*</td> <td rowspan="3">Minor</td> <td rowspan="3">1.5</td> </tr> <tr> <td>$0.3 < D \leq 0.5$</td> <td>4</td> </tr> <tr> <td>$D > 0.5$</td> <td>0</td> </tr> </tbody> </table>	Dimension	Acceptable number	Class Of Defects	AQL Level	$D \leq 0.3$	*	Minor	1.5	$0.3 < D \leq 0.5$	4	$D > 0.5$	0								
Dimension	Acceptable number	Class Of Defects	AQL Level																	
$D \leq 0.3$	*	Minor	1.5																	
$0.3 < D \leq 0.5$	4																			
$D > 0.5$	0																			
$D = (\text{Long} + \text{Short}) / 2$ * : Disregard																				
Foreign Material in Line or spiral shape ($W \leq 1/4L$) (Note: 4)																				
<table border="1"> <thead> <tr> <th>Dimension</th> <th>Acceptable number</th> <th>Class Of Defects</th> <th>AQL Level</th> </tr> </thead> <tbody> <tr> <td>$W > 0.1\text{mm}, L > 5\text{mm}$</td> <td>0</td> <td rowspan="3">Minor</td> <td rowspan="3">1.5</td> </tr> <tr> <td>$L \leq 5\text{mm}, 0.07\text{mm} < W \leq 0.1\text{mm}$</td> <td>4</td> </tr> <tr> <td>$L \leq 5\text{mm}, W < 0.07\text{mm}$</td> <td>*</td> </tr> </tbody> </table>	Dimension	Acceptable number	Class Of Defects	AQL Level	$W > 0.1\text{mm}, L > 5\text{mm}$	0	Minor	1.5	$L \leq 5\text{mm}, 0.07\text{mm} < W \leq 0.1\text{mm}$	4	$L \leq 5\text{mm}, W < 0.07\text{mm}$	*								
Dimension	Acceptable number	Class Of Defects	AQL Level																	
$W > 0.1\text{mm}, L > 5\text{mm}$	0	Minor	1.5																	
$L \leq 5\text{mm}, 0.07\text{mm} < W \leq 0.1\text{mm}$	4																			
$L \leq 5\text{mm}, W < 0.07\text{mm}$	*																			
L : Length W : Width * : Disregard																				
2	External Inspection (non-operating)	Dimension: Outline (Major)																		
		Bezel appearance: uneven (Minor)																		
		Scratch on the Polarize : (Note:2)																		
		<table border="1"> <thead> <tr> <th>Dimension</th> <th>Acceptable number</th> <th>Class Of Defects</th> <th>AQL Level</th> </tr> </thead> <tbody> <tr> <td>$W > 0.1\text{mm}, L > 5\text{mm}$</td> <td>0</td> <td rowspan="3">Minor</td> <td rowspan="3">1.5</td> </tr> <tr> <td>$L \leq 5\text{mm}, 0.07\text{mm} < W \leq 0.1\text{mm}$</td> <td>4</td> </tr> <tr> <td>$L \leq 5\text{mm}, W < 0.07\text{mm}$</td> <td>*</td> </tr> </tbody> </table>	Dimension	Acceptable number	Class Of Defects	AQL Level	$W > 0.1\text{mm}, L > 5\text{mm}$	0	Minor	1.5	$L \leq 5\text{mm}, 0.07\text{mm} < W \leq 0.1\text{mm}$	4	$L \leq 5\text{mm}, W < 0.07\text{mm}$	*						
		Dimension	Acceptable number	Class Of Defects	AQL Level															
		$W > 0.1\text{mm}, L > 5\text{mm}$	0	Minor	1.5															
$L \leq 5\text{mm}, 0.07\text{mm} < W \leq 0.1\text{mm}$	4																			
$L \leq 5\text{mm}, W < 0.07\text{mm}$	*																			
L : Length W : Width * : Disregard																				

Dent and spots shape on the polarize: (Note:2): (Note: 5)			
Dimension	Acceptable number	Class Of Defects	AQL Level
$D \leq 0.3$	*	Minor	1.5
$0.3 < D \leq 0.5$	4		
$D > 0.5$	0		

$D = (\text{Long} + \text{Short}) / 2$ * : Disregard

Class of defects			Definition
	Major	AQL 0.65%	It is a defect that is likely to result in failure or to reduce materially the usability of the product for the intended function.
Minor	AQL 1.5%	It is a defect that will not result in functioning problem with deviation classified.	

Note:1.(a)Bright point defect is defined as point defect of R,G,B with area $>1/2$ dot respectively

(b)Dark point defect is defined as visible in full white pattern.

(c)The point defect must under 2% ND Filter visible .

Note:2 The external inspection should be conducted at the distance 35 ± 5 cm between the eyes of inspector and the panel .

Note:3 Luminance measurement for contrast ratio is at the distance 50 ± 5 cm between the detective head and

the panel with ambient illuminance less than 1 lux. Contrast ratio is obtained at optimum view angle.

Note:4 W-Width in mm , L-length of Max.(L1,L2) in mm.

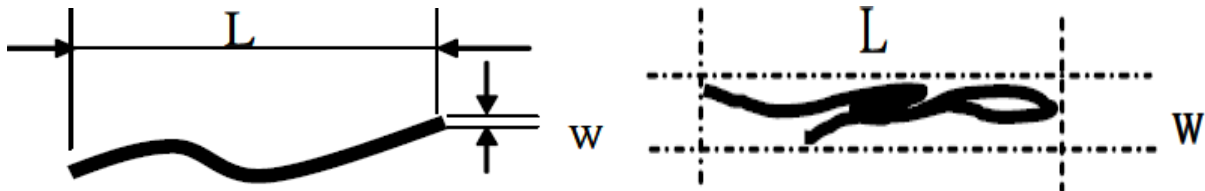

Note:5 Spot Foreign Material ($W \geq L/4$)

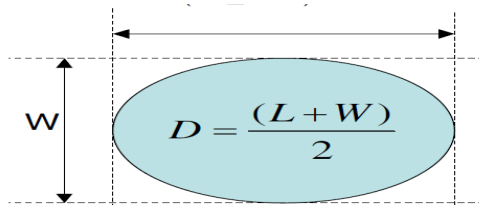

10.3 Sampling Condition

Unless otherwise agree in written, the sampling inspection shall be applied to the incoming inspection of customer.

Lot size: Quantity of shipment lot per model.

Sampling type: normal inspection, single sampling

Sampling table: MIL-STD-105E

Inspection level: Level II

11. LCM Product Label Define

Product Label style:

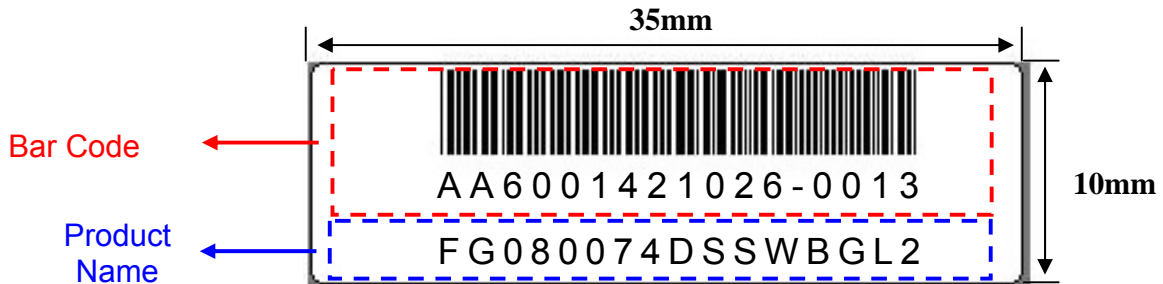

BarCode Define:

A A 6 0014 2 10 26-0013

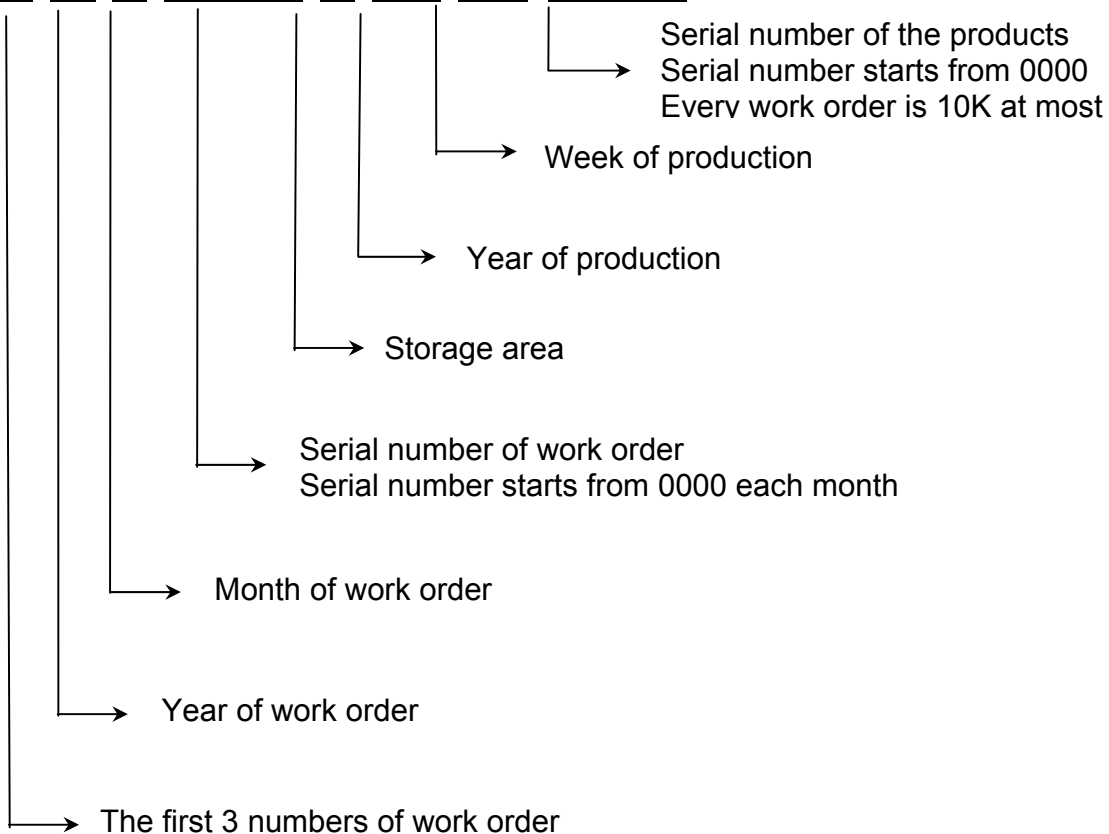

Product Name Define:

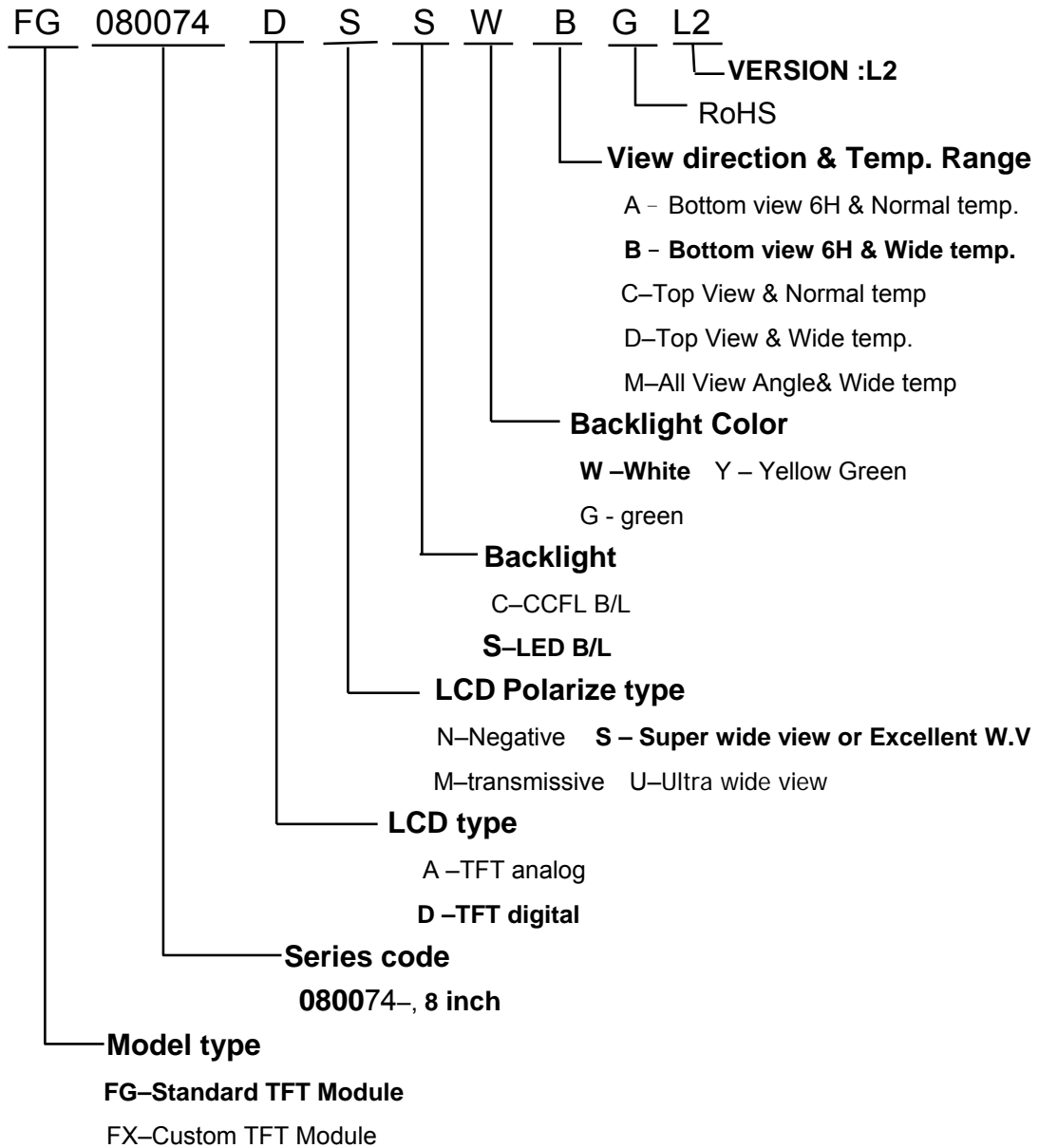

12. PRECAUTIONS IN USE LCM

1. ASSEMBLY PRECAUTIONS

- (1) You must mount a module using holes arranged in four corners or four sides.
- (2) You should consider the mounting structure so that uneven force (ex. Twisted stress) is not applied to the module. And the case on which a module is mounted should have sufficient strength so that external force is not transmitted directly to the module.
- (3) Do not touch, push or rub the exposed polarizers with glass, tweezers or anything harder than HB pencil lead. And please do not rub with dust clothes with chemical treatment.
- (4) Wipe off saliva or water drops as soon as possible. Their long time contact with polarizer causes deformations and color fading.
- (5) Do not open the case because inside circuits do not have sufficient strength.
- (6) Please do not take a LCD module to pieces and reconstruct it. Resolving and reconstructing modules may cause them not to work well.
- (7) Please do not touch metal frames with bare hands and soiled gloves. A color change of the metal frames can happen during a long preservation of soiled LCD modules.
- (8) Please pay attention to handling lead wire of backlight so that it is not tugged in connecting with inverter.

2. OPERATING PRECAUTIONS

- (1) Please be sure to turn off the power supply before connecting and disconnecting signal input cable.
- (2) Please do not change variable resistance settings in LCD module. They are adjusted to the most suitable value. If they are changed, it might happen LCD does not satisfy the characteristics specification
- (3) Be careful for condensation at sudden temperature change. Condensation makes damage to polarizer or electrical contacted parts. And after fading condensation, smear or spot will occur.
- (4) When fixed patterns are displayed for a long time, remnant image is likely to occur.
- (5) Module has high frequency circuits. Sufficient suppression to the electromagnetic interference shall be done by system manufacturers. Grounding and shielding methods may be important to minimize the interference.
- (6) Please consider that LCD backlight takes longer time to become stable of radiation characteristics in low temperature than in room temperature.

3. ELECTROSTATIC DISCHARGE CONTROL

- (1) The operator should be grounded whenever he/she comes into contact with the module. Never touch any of the conductive parts such the copper leads on the PCB and the interface terminals with any

parts of the human body.

- (3) The modules should be kept in antistatic bags or other containers resistant to static for storage.
- (4) Only properly grounded soldering irons should be used.
- (5) If an electric screwdriver is used, it should be well grounded and shielded from commutator sparks.
- (6) The normal static prevention measures should be observed for work clothes and working benches; for the latter conductive (rubber) mat is recommended
- (7) Since dry air is inductive to statics, a relative humidity of 50-60% is recommended.

4. STORAGE PRECAUTIONS

- (1) When you store LCDs for a long time, it is recommended to keep the temperature between 0°C-40°C without the exposure of sunlight and to keep the humidity less than 90%RH.
- (2) Please do not leave the LCDs in the environment of high humidity and high temperature such as 60°C 90%RH
- (3) Please do not leave the LCDs in the environment of low temperature; below -20°C.

5. OTHERS

- (1) A strong incident light into LCD panel might cause display characteristics' changing inferior because of polarizer film, color filter, and other materials becoming inferior. Please do not expose LCD module direct sunlight and strong UV rays
- (2) Please pay attention to a panel side of LCD module not to contact with other materials in preserving it alone.
- (3) For the packaging box, please pay attention to the followings:
- (4) Please do not pile them up more than 5 boxes. (They are not designed so.) And please do not turn over.
- (5) Please handle packaging box with care not to give them sudden shock and vibrations. And also please do not throw them up.
- (6) Packing box and inner case for LCDs are made of cardboard. So please pay attention not to get them wet. (Such like keeping them in high humidity or wet place can occur getting them wet.)

6. LIMITED WARRANTY

Unless otherwise agreed between DATA IMAGE and customer, DATA IMAGE will replace or repair any of its LCD and LCM which is found to be defective electrically and visually when inspected in accordance with DATA IMAGE acceptance standards, for a period on one year from date of shipment. Confirmation of such date shall be based on freight documents. The warranty liability of DATA IMAGE is limited to repair and/or replacement on the terms set forth above. DATA IMAGE will not responsible for any subsequent or consequential events.

Confidential Document
13. OUTLINE DRAWING

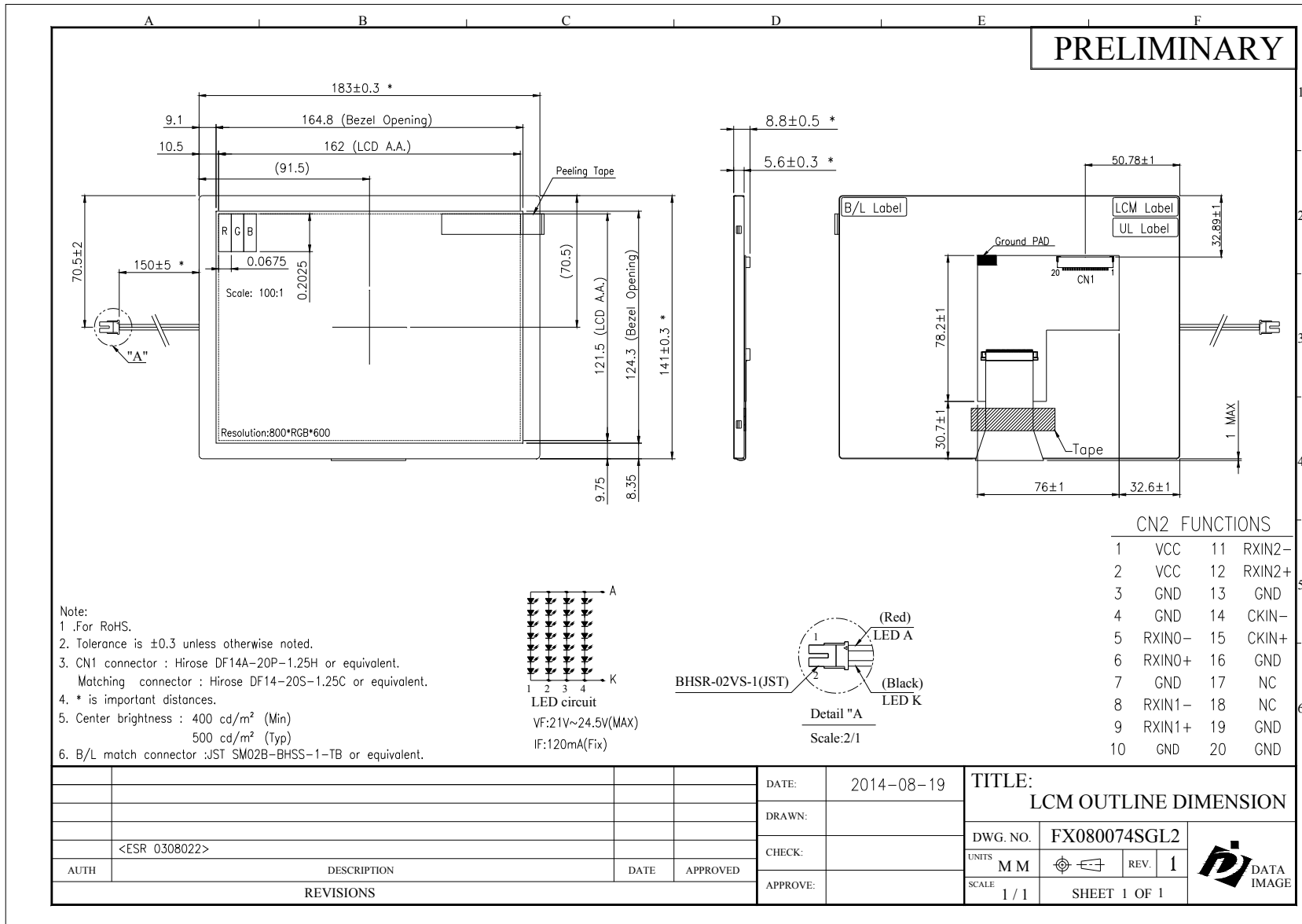

14. PACKAGE INFORMATION

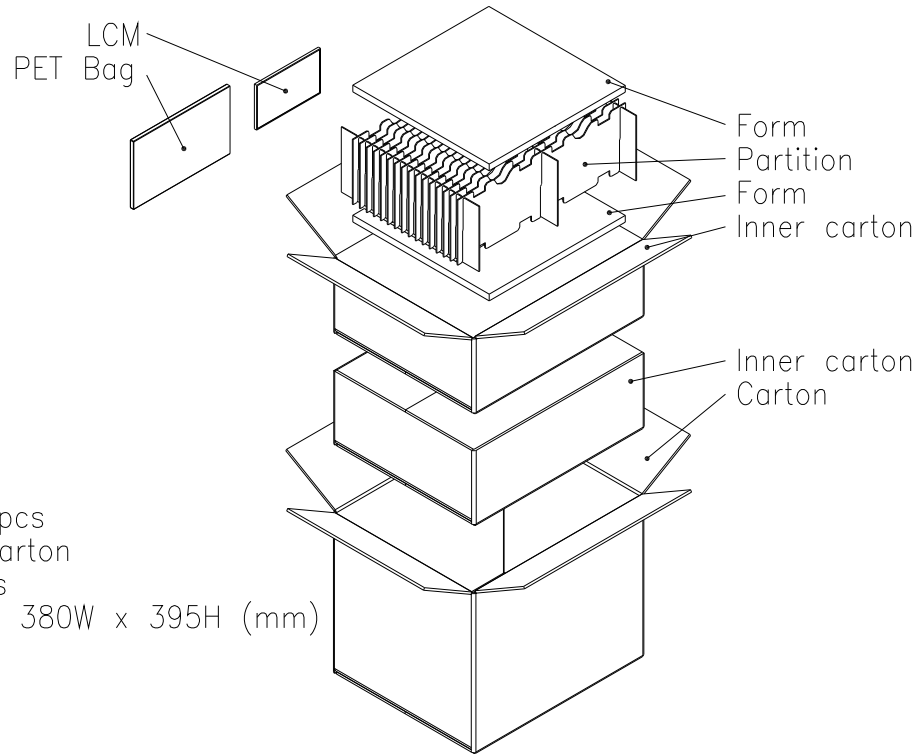

1 Inner carton= 30 pcs
1 Carton= 2 Inner carton
= 30 pcs*2= 60 pcs
Carton size : 465L x 380W x 395H (mm)