



# DATA IMAGE CORPORATION

## TFT Module Specification

ITEM NO.: FG080073DSSWAGT1

### Table of Contents

- 1. COVER & CONTENTS ..... 1
- 2. RECORD OF REVISION ..... 2
- 3. APPLICATION..... 3
- 4. GENERAL SPECIFICATIONS ..... 3
- 5. ABSOLUTE MAXIMUM RATINGS..... 3
- 6. ELECTRICAL CHARACTERISTICS ..... 3
- 7. TIMING CHARACTERISTICS ..... 4
- 8. PIN CONNECTIONS ..... 7
- 9.. BLOCK DIAGRAM..... 9
- 10. OPTICAL CHARACTERISTIC ..... 10
- 11. QUALITY ASSURANCE ..... 13
- 12. TOUCH PANEL CHARACTERISTICS ..... 14
- 13. LCM PRODUCT LABEL DEFINE..... 15
- 14. PRECAUTIONS IN USE LCM ..... 17
- 15. OUTLINE DRAWING ..... 18
- 16. PACKAGE INFORMATION ..... 19

Customer Companies	R&D Dept.	Q.C. Dept.	Eng. Dept.	Prod. Dept.
	ALEX	JOE	GARY	KEN
Approved by	Version:	Issued Date:	Sheet Code:	Total Pages:
	A	22/OCT/12'		19

**2. RECORD OF REVISION**

Rev	Date	Item	Page	Comment
1	30/Nov/11			Initial PRELIMINARY
2	27/Decl/11'	15	18	Modify OUTLINE DRAWING : REV:1 to REV:2.
3	22/JUL/12'	7	4	Modify Timing Characteristics.
A	22/OCT/12'	15	18	1. Modify OUTLINE DRAWING: REV:2 to REV:A. 2. Release Rev: A for production.

### 3. APPLICATION

Digital equipments which need color display, such as P.O.S, medical equipments and industrial equipments.

### 4. GENERAL SPECIFICATIONS

Parameter	Specifications	Unit
Display resolution	800(W) x 600(H)	dot
Active area	162(W) x 121.5(H)	mm
Screen size	8.0"(Diagonal)	inch
Dot pitch	0.0675(W) x 0.2025(H)	mm
Color configuration	R.G.B. Stripe	
Overall dimension	183(W) x 141(H) x 10.26(D)	mm
Weight	350	g
Surface treatment	Anti-glare	
View Angle direction	6 o'clock	
Our components and processes are compliant to RoHS standard		

### 5. ABSOLUTE MAXIMUM RATINGS

Parameter	Symbol	MIN.	MAX.	Unit	Remark
Power supply voltage	V <sub>DD</sub>	-0.3	5.0	V	T <sub>a</sub> =25°C
Operating temperature	Top	-10	60	°C	
Storage temperature	Tst	-30	70	°C	

### 6. ELECTRICAL CHARACTERISTICS

GND= 0V, T<sub>a</sub>=25°C, DCLK=39.79 MHz

Parameter	Symbol	MIN.	Typ.	MAX.	Unit	Remark
Power Supply voltage	V <sub>DD</sub>	3.0	3.3	3.6	V	
Power Supply Current	I <sub>DD</sub>	--	160	240	mA	V <sub>DD</sub> = 3.3V
Input logic high voltage	V <sub>IH</sub>	0.7 V <sub>DD</sub>	-	V <sub>DD</sub>	V	
Input logic low voltage	V <sub>IL</sub>	0	-	0.3 V <sub>DD</sub>	V	

#### 6.1 Backlight Driving for Power Consumption

T<sub>a</sub>= 25 °C

Parameter	Symbol	min	Typ.	Max.	Unit	Remark
VLED voltage	V <sub>L</sub>	9.3	9.9	10.5	V	Note 1, 2
LED current	I <sub>L</sub>	162	180	198	mA	
LED Life Time decay to 50%		20000	--	--	hr	Note 3

Note 1: V<sub>L</sub>=A-K

Note 2: The LED Supply Voltage is defined by the number of LED at T<sub>a</sub>=25°C and I<sub>L</sub> =180mA.

Note 3: The "LED life time" is defined as the module brightness decrease to 50% original brightness at T<sub>a</sub>=25°C and I<sub>L</sub> =180mA. The LED lifetime could be decreased if operating I<sub>L</sub> is larger than 180 mA.

## 7. Timing Characteristics

### 7.1 Input signal characteristics

#### 7.1.1 AC Electrical Characteristics

Parameter	Symbol	MIN.	TYP.	MAX.	Unit
Data setup time	$T_{dsu}$	8	-	-	ns
Data hold time	$T_{dhd}$	8	-	-	ns
DEN setup time	$T_{esu}$	8	-	-	ns

#### 7.1.2 Resolution : 800x600

Parameter	Symbol	MIN.	TYP.	MAX.	Unit
CLK frequency	$F_{CPH}$	-	40	50	MHz
CLK period	$T_{CPH}$	20	25	-	ns
CLK pulse duty	$T_{CWH}$	40	50	60	%
DE period	$T_{DEH}+T_{DEL}$	862	1056	1200	$T_{CPH}$
DE pulse width	$T_{DH}$	-	800	-	$T_{CPH}$
DE frame blanking	$T_{DEB}$	24	35	100	$T_{DEH}+T_{DEL}$
DE frame width	$T_{DE}$	-	600	-	$T_{DEH}+T_{DEL}$

## 7.2 Timing Controller Timing Chart

### 6.2.1 Clock and Data input waveforms

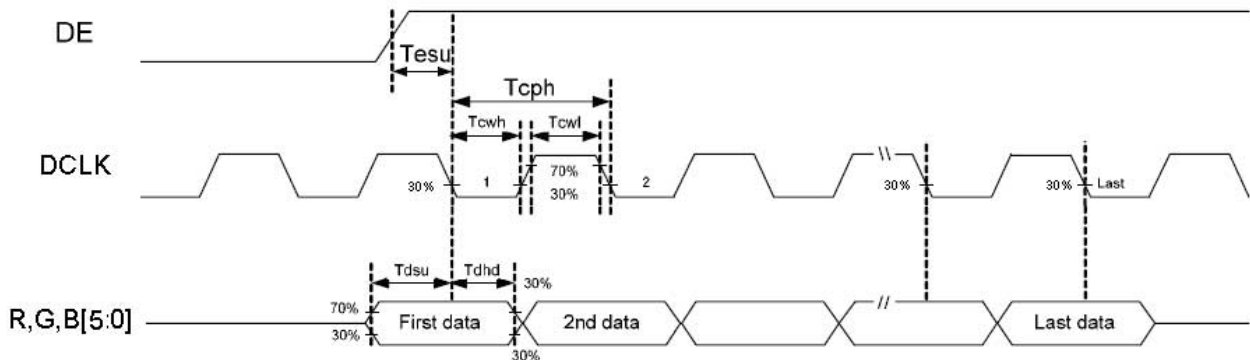
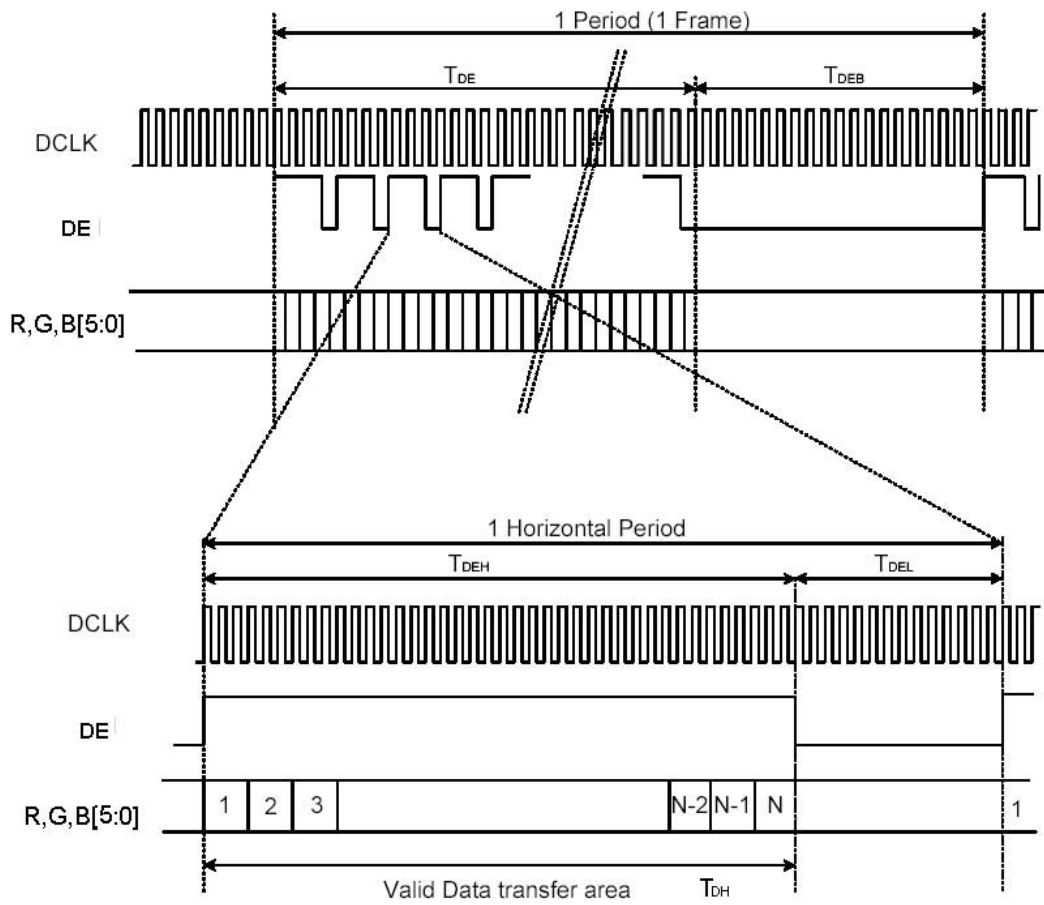

Figure 1 Clock and Data input waveforms.



N=800

Figure 2 DE Mode Data Format

### 7.3 Color Data Input Assignment

		Data Signal																	
		Red						Green						Blue					
Color		R5	R4	R3	R2	R1	R0	G5	G4	G3	G2	G1	G0	B5	B4	B3	B2	B1	B0
Basic Colors	Black	0	0	0	0	0	0	0	0	0	0	0	0	0	0	0	0	0	0
	Red	1	1	1	1	1	1	0	0	0	0	0	0	0	0	0	0	0	0
	Green	0	0	0	0	0	0	1	1	1	1	1	1	0	0	0	0	0	0
	Blue	0	0	0	0	0	0	0	0	0	0	0	0	1	1	1	1	1	1
	Cyan	0	0	0	0	0	0	1	1	1	1	1	1	1	1	1	1	1	1
	Magenta	1	1	1	1	1	1	0	0	0	0	0	0	1	1	1	1	1	1
	Yellow	1	1	1	1	1	1	1	1	1	1	1	1	0	0	0	0	0	0
	White	1	1	1	1	1	1	1	1	1	1	1	1	1	1	1	1	1	1
Gray Scale of Red	Red(0) / Dark	0	0	0	0	0	0	0	0	0	0	0	0	0	0	0	0	0	0
	Red(1)	0	0	0	0	0	1	0	0	0	0	0	0	0	0	0	0	0	0
	Red(2)	0	0	0	0	1	0	0	0	0	0	0	0	0	0	0	0	0	0
	:	:	:	:	:	:	:	:	:	:	:	:	:	:	:	:	:	:	:
	:	:	:	:	:	:	:	:	:	:	:	:	:	:	:	:	:	:	:
	Red(61)	1	1	1	1	0	1	0	0	0	0	0	0	0	0	0	0	0	0
	Red(62)	1	1	1	1	1	0	0	0	0	0	0	0	0	0	0	0	0	0
Red(63)	1	1	1	1	1	1	0	0	0	0	0	0	0	0	0	0	0	0	
Gray Scale of Green	Green(0)/ Dark	0	0	0	0	0	0	0	0	0	0	0	0	0	0	0	0	0	0
	Green(1)	0	0	0	0	0	0	0	0	0	0	0	1	0	0	0	0	0	0
	Green(2)	0	0	0	0	0	0	0	0	0	0	1	0	0	0	0	0	0	
	:	:	:	:	:	:	:	:	:	:	:	:	:	:	:	:	:	:	
	:	:	:	:	:	:	:	:	:	:	:	:	:	:	:	:	:	:	
	Green(61)	0	0	0	0	0	0	1	1	1	1	0	1	0	0	0	0	0	0
	Green(62)	0	0	0	0	0	0	1	1	1	1	1	0	0	0	0	0	0	0
Green(63)	0	0	0	0	0	0	1	1	1	1	1	1	0	0	0	0	0	0	
Gray Scale of Blue	Blue(0)/ Dark	0	0	0	0	0	0	0	0	0	0	0	0	0	0	0	0	0	0
	Blue (1)	0	0	0	0	0	0	0	0	0	0	0	0	0	0	0	0	0	1
	Blue (2)	0	0	0	0	0	0	0	0	0	0	0	0	0	0	0	0	1	0
	:	:	:	:	:	:	:	:	:	:	:	:	:	:	:	:	:	:	:
	:	:	:	:	:	:	:	:	:	:	:	:	:	:	:	:	:	:	:
	Blue (61)	0	0	0	0	0	0	0	0	0	0	0	0	1	1	1	1	0	1
	Blue (62)	0	0	0	0	0	0	0	0	0	0	0	0	1	1	1	1	1	0
Blue (63)	0	0	0	0	0	0	0	0	0	0	0	0	1	1	1	1	1	1	

## 8. PIN CONNECTIONS

### 8.1 Input Pins Function

Pin No.	Symbol	Function	Remark
1	A	Power for LED backlight anode	
2	A	Power for LED backlight anode	
3	K	Power for LED backlight cathode	
4	K	Power for LED backlight cathode	
5	GND	Power ground	
6	GND	Power ground	
7	VDD	Power for Digital circuit	
8	VDD	Power for Digital circuit	
9	VDD	Power for Digital circuit	
10	VDD	Power for Digital circuit	
11	DE	Data Input Enable	
12	GND	Power ground	
13	B5	Blue data	
14	B4	Blue data	
15	B3	Blue data	
16	GND	Power ground	
17	B2	Blue data	
18	B1	Blue data	
19	B0	Blue data(LSB)	
20	GND	Power ground	
21	G5	Green data	
22	G4	Green data	
23	G3	Green data	
24	GND	Power ground	
25	G2	Green data	
26	G1	Green data	
27	G0	Green data (LSB)	
28	GND	Power ground	
29	R5	Red data	
30	R4	Red data	
31	R3	Red data	
32	GND	Power ground	
33	R2	Red data	
34	R1	Red data	
35	R0	Red data (LSB)	
36	GND	Power ground	
37	GND	Power ground	
38	DCLK	Sample clock	
39	GND	Power ground	
40	GND	Power ground	

### 8.2 Touch panel pin define

Pin No.	Symbol	Description	Remark
1	Top	Touch panel top	
2	Right	Touch panel right	
3	Bottom	Touch panel bottom	
4	Left	Touch panel left	

### 8.3 Power Signal Sequence

Remarks:

\*1) Power Signal sequence:

$t1 \leq 10ms$  :  $1 \text{ sec} \leq t5$

$50ms \leq t2$  :  $200ms \leq t6$

$0 < t3 \leq 50ms$ :  $200ms \leq t7$

$0 < t4 \leq 10ms$

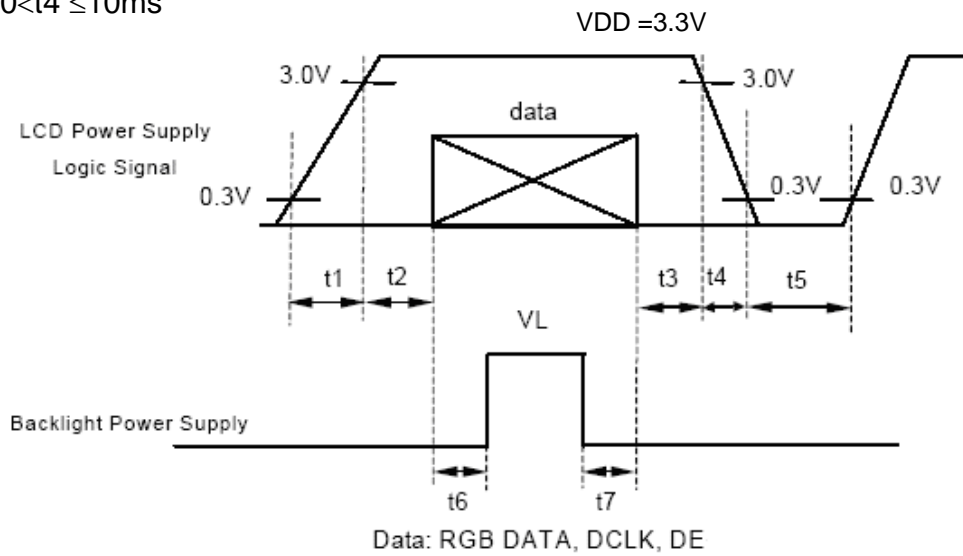



### 9. BLOCK DIAGRAM

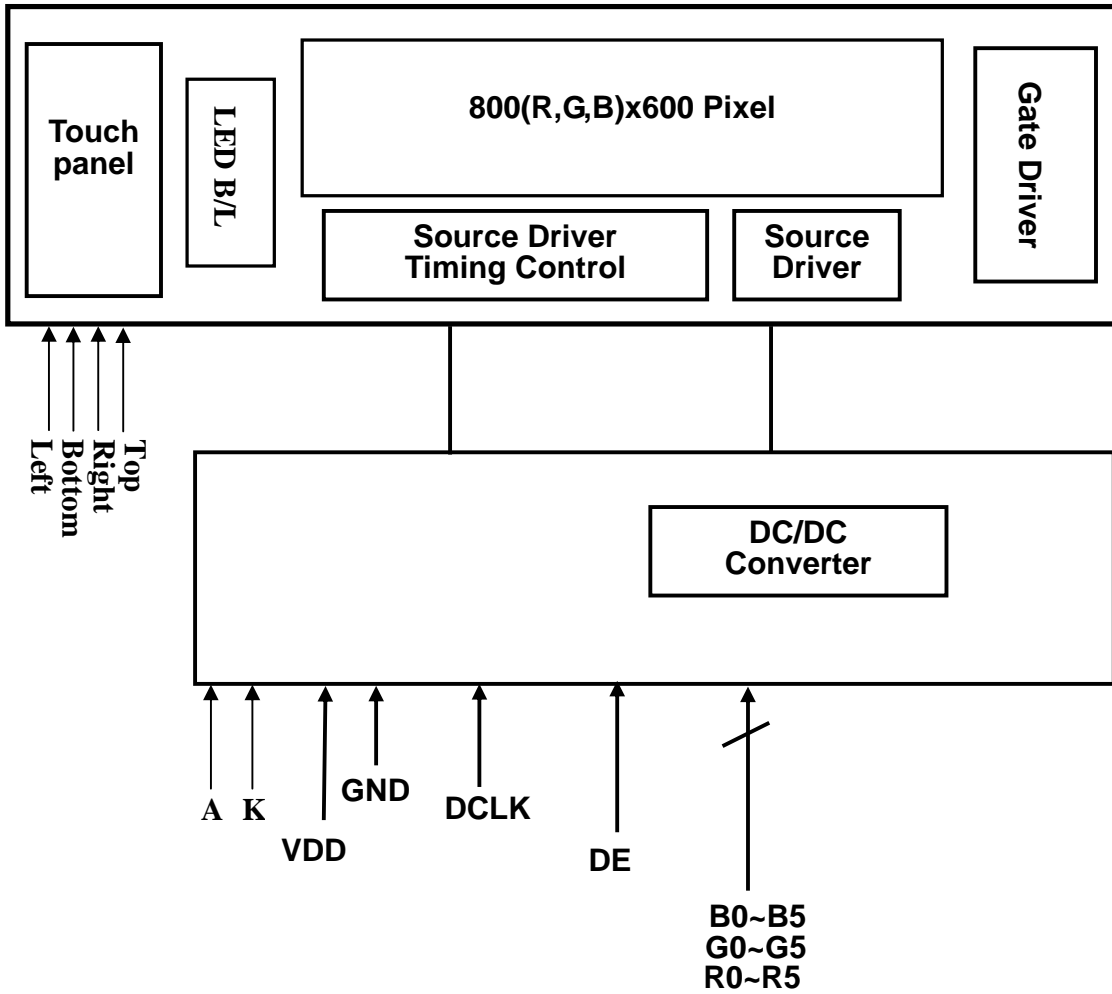

## 10. OPTICAL CHARACTERISTIC

### 10.1. Specification:

Item		Symbol	Condition	Min.	Typ.	Max.	Unit	Remark
Response time	Rise	T <sub>ON</sub>	Normal $\theta=\Phi=0^\circ$	-	10	20	ms	Note 3
	Fall	T <sub>OFF</sub>		-	15	30	ms	
Contrast ratio		CR		320	400			Note 4
White chromaticity		X		0.26	0.31	0.36		Note2,5,6
		y		0.28	0.33	0.38		
Viewing angle	$\theta_L$	$\Phi=180^\circ$ (9 o'clock)		60	70	-	Deg.	Note 1
	$\theta_R$	$\Phi=0^\circ$ (3 o'clock)	60	70	-			
	$\theta_T$	$\Phi=90^\circ$ (12 o'clock)	40	50	-			
	$\theta_B$	$\Phi=270^\circ$ (6 o'clock)	60	70	-			
Brightness			Normal $\theta=\Phi=0^\circ$	160	200	--	cd/m <sup>2</sup>	Note 6
Uniformity				70	75		%	Note 7
Image sticking		tis	2 hours			2	Sec	Note 8

Test Conditions:

- VCC=3.3V, IL=180mA (Backlight current), the ambient temperature is 25°C.
- The test systems refer to Note 2.

Note 1: Definition of viewing angle range

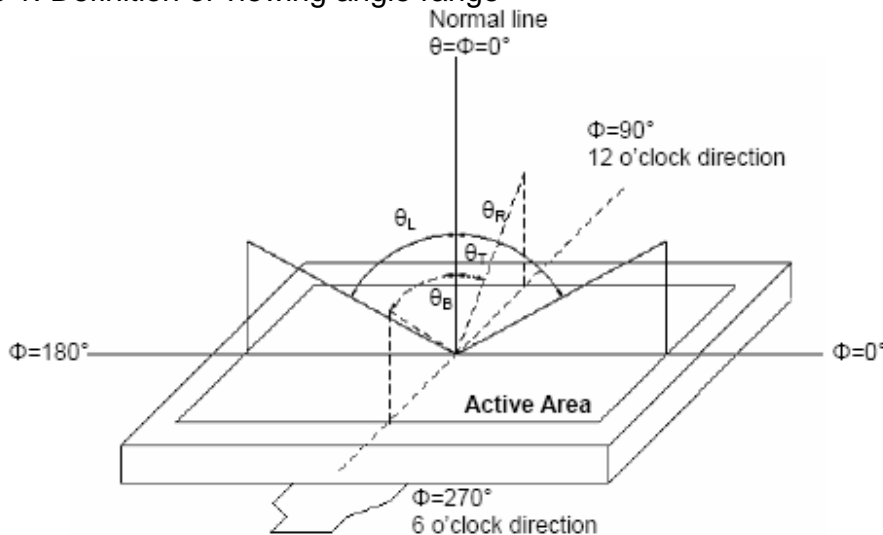

**Fig.10-1 Definition of viewing angle**

Note 2: Definition of optical measurement system.

The optical characteristics should be measured in dark room. After 2 minutes operation, the optical properties are measured at the center point of the LCD screen. (Response time is measured by Photo detector TOPCON BM-7A, other items are measured by BM-7A/Field of view: 1° /Height: 500mm.)

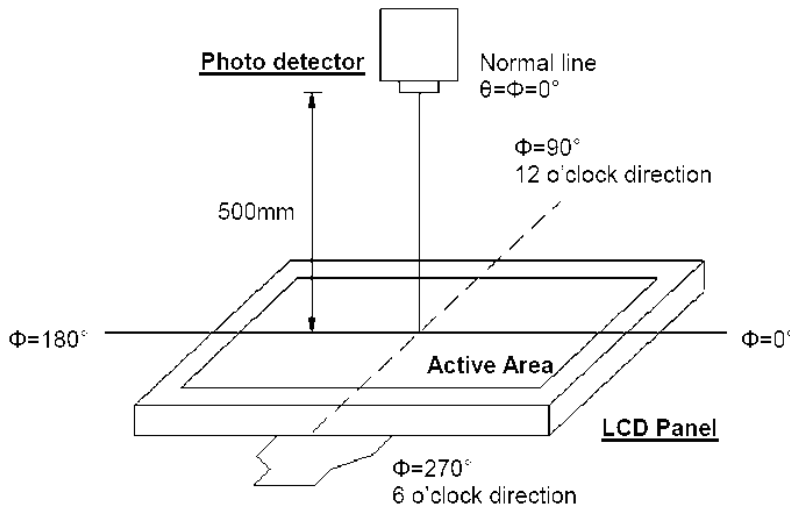

**Fig. 10-2 Optical measurement system setup**

**Note 3: Definition of Response time**

The response time is defined as the LCD optical switching time interval between “White” state and “Black” state. Rise time (TON) is the time between photo detector output intensity changed from 90% to 10%. And fall time (TOFF) is the time between photo detector output intensity changed from 10% to 90%.

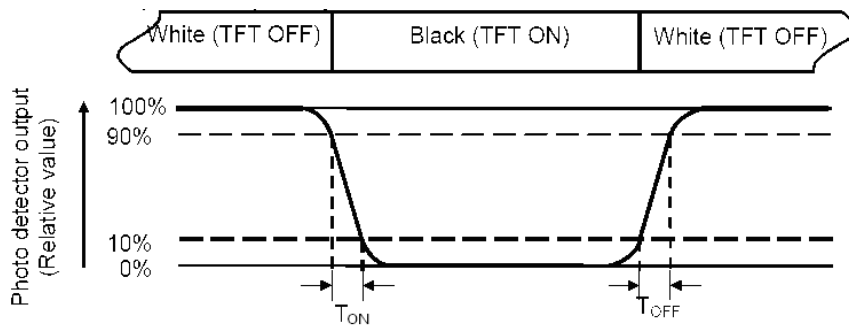

**Fig. 10-3 Definition of response time**

**Note 4: Definition of contrast ratio**

$$\text{Contrast ratio (CR)} = \frac{\text{Luminance measured when LCD on the "White" state}}{\text{Luminance measured when LCD on the "Black" state}}$$

**Note 5: Definition of color chromaticity (CIE1931)**

Color coordinates measured at center point of LCD.

**Note 6:** Measured at the center area of the panel when LCD panel is driven at “white” state. The LED driving condition is IL=180mA.

**Note 7: Definition of Luminance Uniformity**

Active area is divided into 9 measuring areas (Refer to Fig. 10-4 ).Every measuring point is placed at the center of each measuring area.

$$\text{Luminance Uniformity (Yu)} = \frac{B_{min}}{B_{max}}$$

L-----Active area length    W----- Active area width

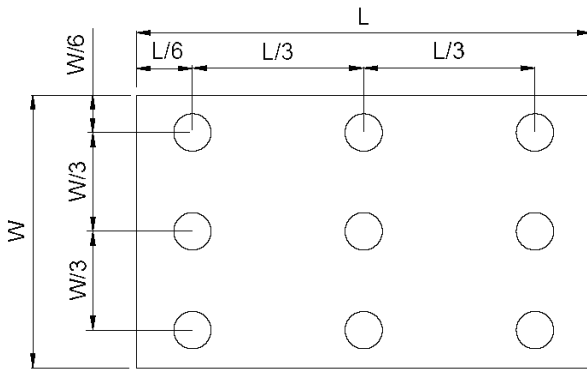

**Fig. 10-4 Definition of measuring points**

$B_{max}$ : The measured maximum luminance of all measurement position.

$B_{min}$ : The measured minimum luminance of all measurement position.

**Note 8: Definition of Image sticking (tis):**

Continuously display the test pattern shown in the figure below for 2 hours. Then display a completely white screen. The previous image shall not persist more than 2 sec at 25 °C

**Image sticking pattern**

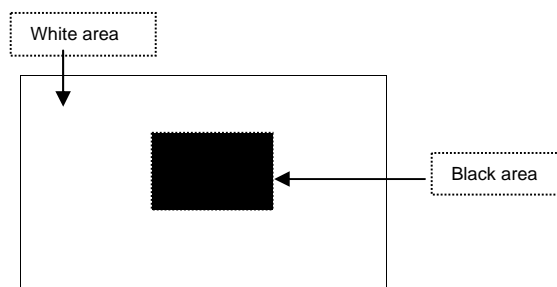

## 11. TOUCH PANEL CHARACTERISTICS

### 1. Input Method and Activation Force

Input Method	Average Activation Force
1.6mm dia. Delrin stylus	50gf Max.
16mm dia. Silicon "finger"	50gf Max.

### 2. Typical Optical Characteristics

ITEM	Parameter
Visible Light Transmission	82% typ.
Haze	5% typ.

### 3. Electrical Specification

ITEM	Parameter
Operating Voltage	DC 7V Max.
Circuit close resistance	X 300~1100Ω
	Y 150~650Ω
Circuit open resistance	≥20MΩ at 25V DC
Contact bounce	≤10ms
Linear Test	≤1.5%

### 4. Linearity

ITEM	Parameter
Linear Test Specification Direction	X ≤1.5%
	Y ≤1.5%

### 5. Specification

ITEM	Parameter
Operating Temperature	-10°C~+60°C
Storage Temperature	-30°C~+70°C

### 6. Durability test:

#### 6.1 Finger touches

Touch panel is hit 1 millions times with a silicone rubber of R8 finger, hitting rate is by 200g at 2 times per second. The measurement must satisfy the following:

- Circuit close resistance: x 300~1100Ω ;  
y 150~650Ω
- Circuit open resistance: ≥20MΩ at 25V DC
- Contact bounce: ≤10ms
- Linearity test: ≤3%

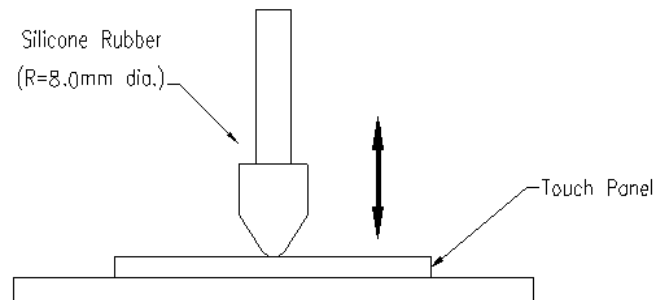

#### 6.2 Stylus writing

Touch panel is drawn by R0.8 Derlin stylus pen, at 250g forces, repeat one inch by 100k times. The measurement must satisfy the following:

- Circuit close resistance: x 300~1100Ω ;  
y 150~650Ω
- Circuit open resistance: ≥20MΩ at 25V DC
- Contact bounce: ≤10ms
- Linearity test: ≤3%

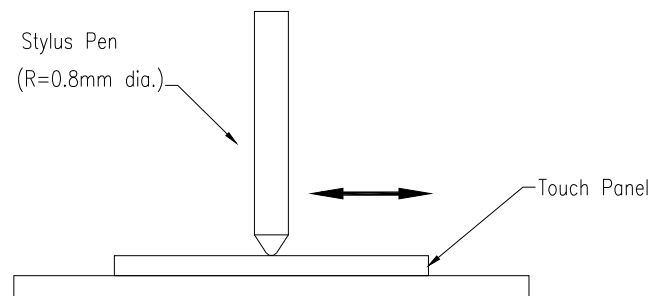

## 12. QUALITY ASSURANCE

### 12.1 Test Condition

#### 12.1.1 Temperature and Humidity(Ambient Temperature)

Temperature :  $25 \pm 5^{\circ}\text{C}$

Humidity :  $65 \pm 5\%$

#### 12.1.2 Operation

Unless specified otherwise, test will be conducted under function state.

#### 12.1.3 Container

Unless specified otherwise, vibration test will be conducted to the product itself without putting it in a container.

#### 12.1.4 Test Frequency

In case of related to deterioration such as shock test. It will be conducted only once.

#### 12.1.5 Test Method

Reliability Test Item & Level		Test Level
No.	Test Item	
1	High Temperature Storage Test	T=70°C,240hrs
2	Low Temperature Storage Test	T=-30°C,240hrs
3	High Temperature Operation Test	T=60°C,240hrs
4	Low Temperature Operation Test	T=-10°C,240hrs
5	High Temperature and High Humidity Operation Test	T=40°C,90%RH,240hrs
6	Thermal Cycling Test (No operation)	-30°C → +25°C → +70°C,100 Cycles 30 min    5 min    30 min
7	Vibration Test (No operation)	Frequency : 10 ~ 55 Hz Amplitude : 1.5 mm Sweep Time : 11mins Test Period : 6 cycles for each Direction of X,Y,Z
8	Shock Test (No operation)	100G, 6ms Direction : ± X,± Y,± Z Cycle : 3 times

### 13. LCM PRODUCT LABEL DEFINE

Product Label style:

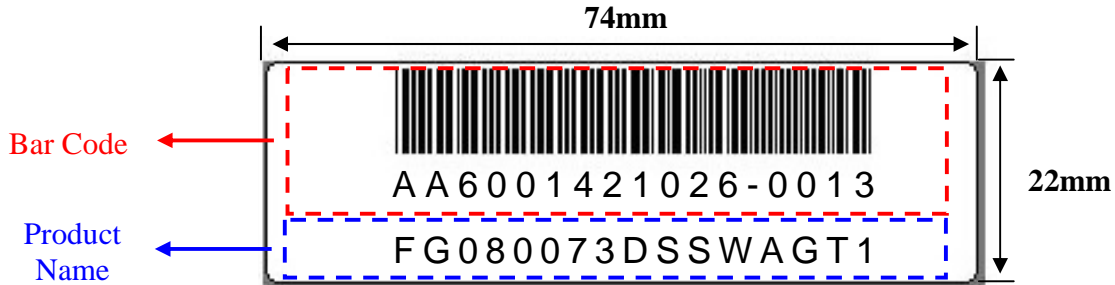

BarCode Define:

**A A 6 0014 2 10 26-0013**

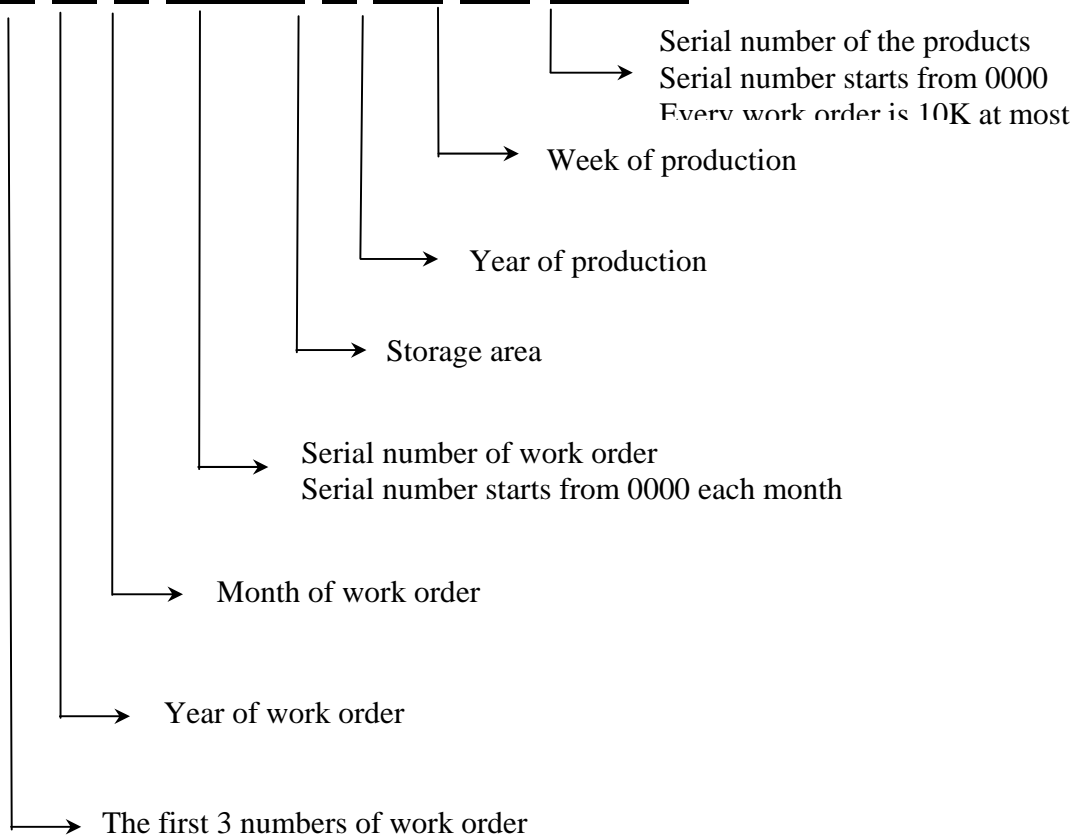

**Product Name Define:**

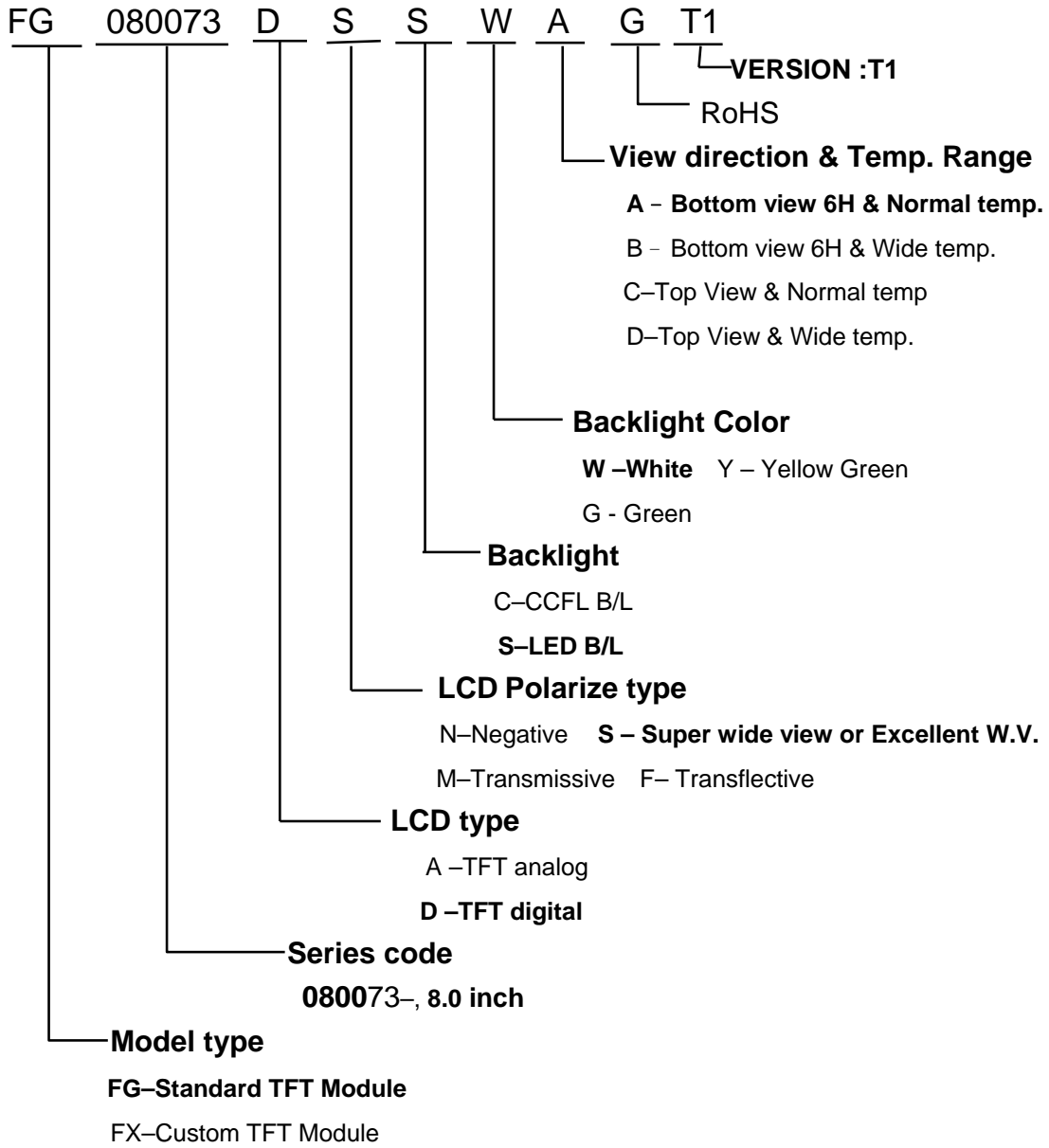



## 14. PRECAUTIONS IN USE LCM

### 1. ASSEMBLY PRECAUTIONS

- (1) You must mount a module using holes arranged in four corners or four sides.
- (2) You should consider the mounting structure so that uneven force (ex. Twisted stress) is not applied to the module. And the case on which a module is mounted should have sufficient strength so that external force is not transmitted directly to the module.
- (3) Do not touch, push or rub the exposed polarizers with glass, tweezers or anything harder than HB pencil lead. And please do not rub with dust clothes with chemical treatment.
- (4) Wipe off saliva or water drops as soon as possible. Their long time contact with polarizer causes deformations and color fading.
- (5) Do not open the case because inside circuits do not have sufficient strength.
- (6) Please do not take a LCD module to pieces and reconstruct it. Resolving and reconstructing modules may cause them not to work well.
- (7) Please do not touch metal frames with bare hands and soiled gloves. A color change of the metal frames can happen during a long preservation of soiled LCD modules.
- (8) Please pay attention to handling lead wire of backlight so that it is not tugged in connecting with inverter.

### 2. OPERATING PRECAUTIONS

- (1) Please be sure to turn off the power supply before connecting and disconnecting signal input cable.
- (2) Please do not change variable resistance settings in LCD module. They are adjusted to the most suitable value. If they are changed, it might happen LCD does not satisfy the characteristics specification
- (3) Be careful for condensation at sudden temperature change. Condensation makes damage to polarizer or electrical contacted parts. And after fading condensation, smear or spot will occur.
- (4) When fixed patterns are displayed for a long time, remnant image is likely to occur.
- (5) Module has high frequency circuits. Sufficient suppression to the electromagnetic interference shall be done by system manufacturers. Grounding and shielding methods may be important to minimize the interference.
- (6) Please consider that LCD backlight takes longer time to become stable of radiation characteristics in low temperature than in room temperature.

### 3. ELECTROSTATIC DISCHARGE CONTROL

- (1) The operator should be grounded whenever he/she comes into contact with the module. Never touch any of the conductive parts such the copper leads on the PCB and the interface terminals with any parts of the human body.

- (2) The modules should be kept in antistatic bags or other containers resistant to static for storage.
- (3) Only properly grounded soldering irons should be used.
- (4) If an electric screwdriver is used, it should be well grounded and shielded from commutator sparks.
- (5) The normal static prevention measures should be observed for work clothes and working benches; for the latter conductive (rubber) mat is recommended
- (6) Since dry air is inductive to statics, a relative humidity of 50-60% is recommended.

### 4. STORAGE PRECAUTIONS

- (1) When you store LCDs for a long time, it is recommended to keep the temperature between 0°C-40°C without the exposure of sunlight and to keep the humidity less than 90%RH.
- (2) Please do not leave the LCDs in the environment of high humidity and high temperature such as 60°C 90%RH
- (3) Please do not leave the LCDs in the environment of low temperature; below -20°C.

### 5. OTHERS

- (1) A strong incident light into LCD panel might cause display characteristics' changing inferior because of polarizer film, color filter, and other materials becoming inferior. Please do not expose LCD module direct sunlight and strong UV rays
- (2) Please pay attention to a panel side of LCD module not to contact with other materials in preserving it alone.
- (3) For the packaging box, please pay attention to the followings:
  - a. Please do not pile them up more than 5 boxes. (They are not designed so.) And please do not turn over.
  - b. Please handle packaging box with care not to give them sudden shock and vibrations. And also please do not throw them up.
  - c. Packing box and inner case for LCDs are made of cardboard. So please pay attention not to get them wet. (Such like keeping them in high humidity or wet place can occur getting them wet.)

### 6. LIMITED WARRANTY

Unless otherwise agreed between DATA IMAGE and customer, DATA IMAGE will replace or repair any of its LCD and LCM which is found to be defective electrically and visually when inspected in accordance with DATA IMAGE acceptance standards, for a period on one year from date of shipment. Confirmation of such date shall be based on freight documents. The warranty liability of DATA IMAGE is limited to repair and/or replacement on the terms set forth above. DATA IMAGE will not responsible for any subsequent or consequential events.

### 15. OUTLINE DRAWING

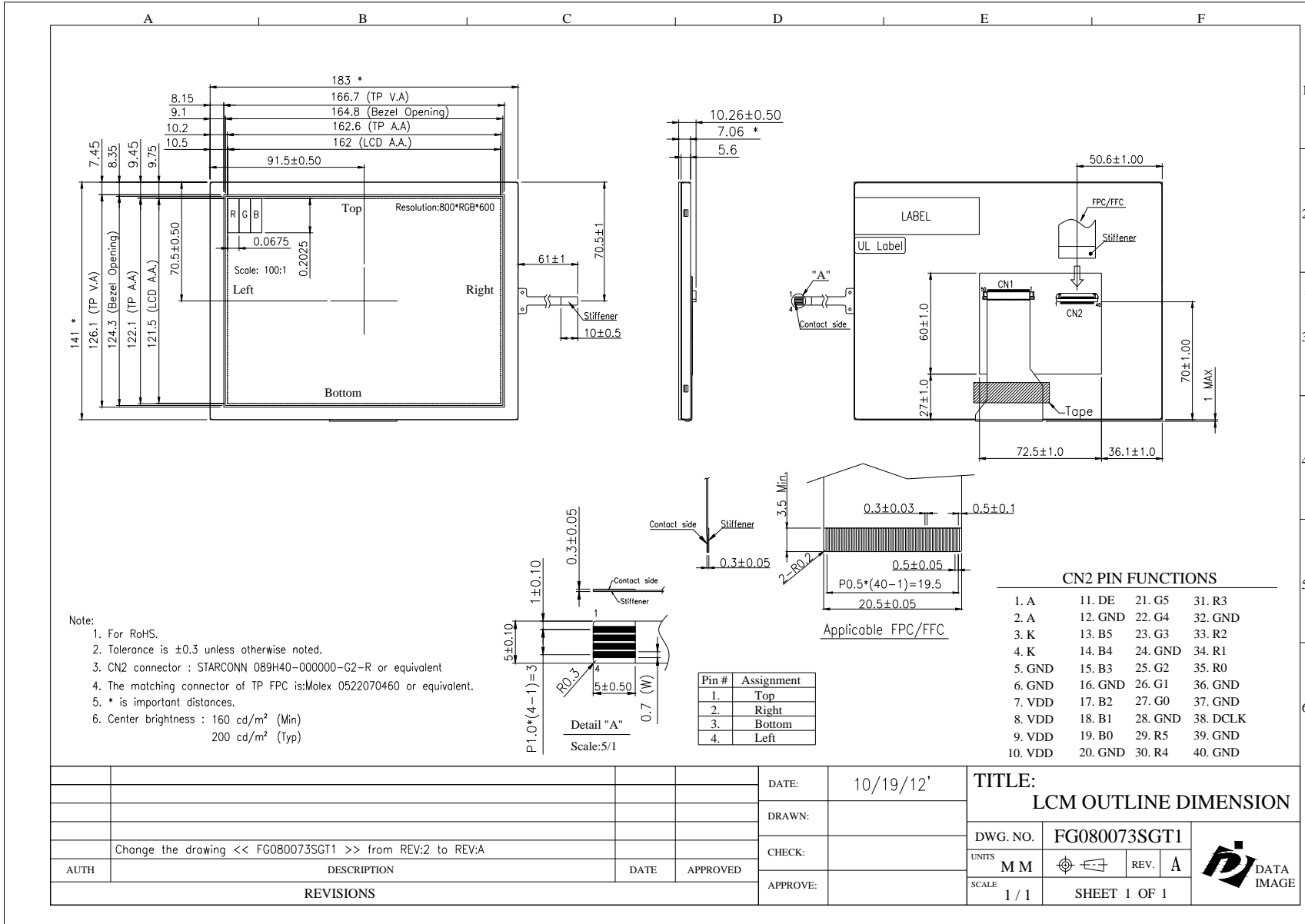

### 16. PACKAGE INFORMATION

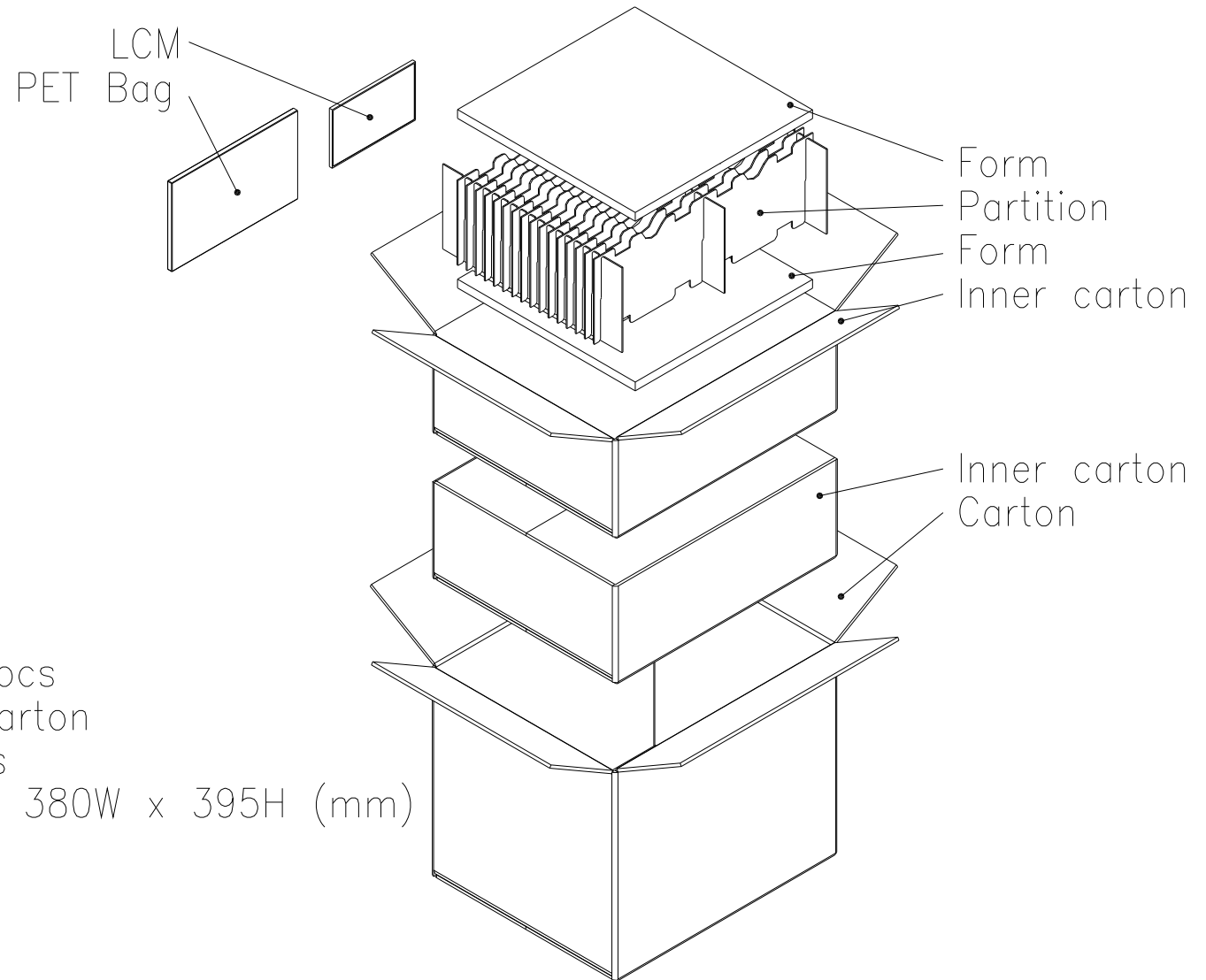

1 Inner carton= 30 pcs  
1 Carton= 2 Inner carton  
= 30 pcs\*2= 60 pcs  
Carton size : 465L x 380W x 395H (mm)