



# DATA IMAGE CORPORATION

## TFT Module Specification

ITEM NO.: FG0700K6DSSWBG01

### Table of Contents

- 1. COVER & CONTENTS ..... 1
- 2. RECORD OF REVISION ..... 2
- 3. APPLICATION..... 3
- 4. GENERAL SPECIFICATIONS ..... 3
- 5. ABSOLUTE MAXIMUM RATINGS ..... 3
- 6. ELECTRICAL CHARACTERISTICS ..... 3
- 7. TIMING SPECIFICATIONS ..... 4
- 8. OPTICAL CHARACTERISTIC ..... 8
- 9. PIN CONNECTIONS ..... 11
- 10. BLOCK DIAGRAM ..... 13
- 11. QUALITY ASSURANCE ..... 14
- 12. LCM PRODUCT LABEL DEFINE..... 18
- 13. PRECAUTIONS IN USE LCM ..... 20
- 14. OUTLINE DRAWING ..... 21
- 15. PACKAGE INFORMATION..... 22

Customer Companies	R&D Dept.	Q.C. Dept.	Eng. Dept.	Prod. Dept.
	<i>Alex</i>	<i>pretty</i>	<i>David</i>	<i>Ken</i>
Approved by	Version:	Issued Date:	Sheet Code:	Total Pages:
	C	18/MAR/15'		22

**2. RECORD OF REVISION**

Rev	Date	Item	Page	Comment	Source
1	18/DEC/09'			Initial PRELIMINARY	ESR9812001
2	12/JUL/10'	1 4 8 14 15	1 3 8 18 19	1.Change Table of contents item 12 2.Modify Outline Dimension & Add the weight 3.Add RGB Chromaticity value. 4.Change OUTLINE DRAWING from Rev:1 to Rev:2 5.Add the weight of PACKAGE INFORMATION	11S-A60013
A	31/DEC/10'	14	18	1.Modify OUTLINE DRAWING from Rev. 2 to A Release Rev. A for production	
B	16/AUG/14'	8 11.2 14	8 15 18	Modify the model Brightness. Add Inspection conditions. Modify the OUTLINE DRAWING form Rev. A to B.	110-E70027
C	18/MAR/15'	6	3	Update lifetime from 20K to 40K hours	11S-F30011

### 3. APPLICATION

DVD player, Car TV, UMPC, POS

### 4. GENERAL SPECIFICATIONS

Parameter	Specifications	Unit
Screen Size	7 (diagonal)	inch
Display Format	800(H) x (R,G,B) x 480(V)	dot
Active Area	152.4(H) x 91.44(V)	mm
Dot Pitch	0.0635 (H) x 0.1905 (V)	mm
Pixel Configuration	Stripe	
Outline Dimension	165(W) x 104.44(H) x 9.7 (D) Max	mm
Surface treatment	Anti-glare	
Back-light	LED	
Display mode	Normally white	
Weight	132	g
View Angle direction	6 o'clock	

### 5. ABSOLUTE MAXIMUM RATINGS

Parameter	Symbol	MIN.	MAX.	Unit	Remark
Power supply voltage	V <sub>CC</sub>	-0.3	6.0	V	Ta=25°C
Logic input voltage	V <sub>I</sub>	-0.3	V <sub>CC</sub> +0.3	V	
Operating temperature	T <sub>OP</sub>	-20	+70	°C	Module surface*
Storage temperature	T <sub>ST</sub>	-30	+80	°C	-
Humidity	Operation	20%~90% relative humidity			Ta<=38°C
	Non Operation	5%~90% relative humidity			Ta<=38°C

### 6. ELECTRICAL CHARACTERISTICS

f<sub>H</sub>=30KHz, f<sub>V</sub>=60Hz, f<sub>CLK</sub>=33.3MHz, Ta=25°C

Parameter	Symbol	MIN.	Typ.	MAX.	Unit	Remark
Power Supply voltage for LCD	V <sub>CC</sub>	+3.0	+3.3	+3.6	V	
Power Supply Current for LCD	I <sub>CC</sub>		150	200	mA	V <sub>CC</sub> =3.3V
Power Supply voltage for LED	V <sub>DD</sub>	3	3.3	5.5	V	
Power Supply Current for LED	I <sub>DD</sub>		650	850	mA	V <sub>DD</sub> =3.3V
Power Supply Current for LED	I <sub>DD</sub>		400	550	mA	V <sub>DD</sub> =5.0V
Ripple voltage	V <sub>RF</sub>	-	-	100	mV <sub>P-P</sub>	
ADJ frequency		19K	20K	21K	Hz	
ADJ input voltage	V <sub>IH</sub>	3.0	-	3.3	V	
	V <sub>IL</sub>	0	-	0.3	V	
Differential Input High Threshold	V <sub>TH</sub>	-	-	100	[mV]	V <sub>CM</sub> =1.2V Note 1
Differential input Low Threshold	V <sub>TL</sub>	-100	-	-	[mV]	
LED dice life time			40,000		Hr	Note 2

Note 1: LVDS Signal Waveform.

### Differential Signal

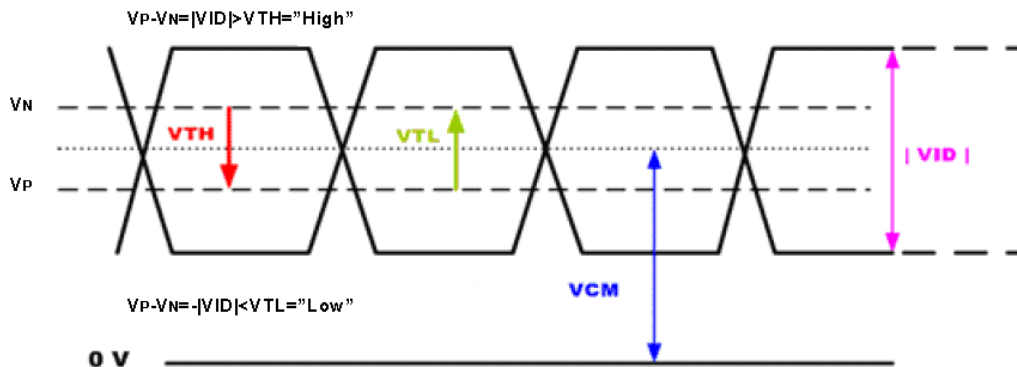

Note 2: The "LED dice life time" is defined as the brightness decrease to 50% original brightness that the ambient temperature is 18 ~28 and LED dice current=20mA.

## 7. INPUT SIGNAL CHARACTERISTICS

### 7.1 AC Characteristics

#### 7.1.1 AC Electrical Characteristics

Parameter	Symbol	MIN.	TYP.	MAX.	Unit
Data setup time	$T_{dsu}$	6	-	-	ns
Data hold time	$T_{dhd}$	6	-	-	ns
DE setup time	$T_{esu}$	6	-	-	ns

#### 7.1.2 Resolution : 800x480

Parameter	Symbol	MIN.	TYP.	MAX.	Unit
DCLK frequency	$F_{CPH}$	25	33.26	40	MHz
DCLK period	$T_{CPH}$	-	30.06	-	ns
DCLK pulse duty	$T_{CWH}$	40	50	60	%
DE period	$T_{DEH} + T_{DEL}$	1000	1056	1200	$T_{CPH}$
DE pulse width	$T_{DEH}$	-	800	-	$T_{CPH}$
DE frame blanking	$T_{DEB}$	10	45	110	$T_{DEH} + T_{DEL}$
DE frame width	$T_{DE}$	-	480	-	$T_{DEH} + T_{DEL}$

### 7.2 Timing Controller Timing Chart

#### 7.2.1 Clock and Data input waveforms

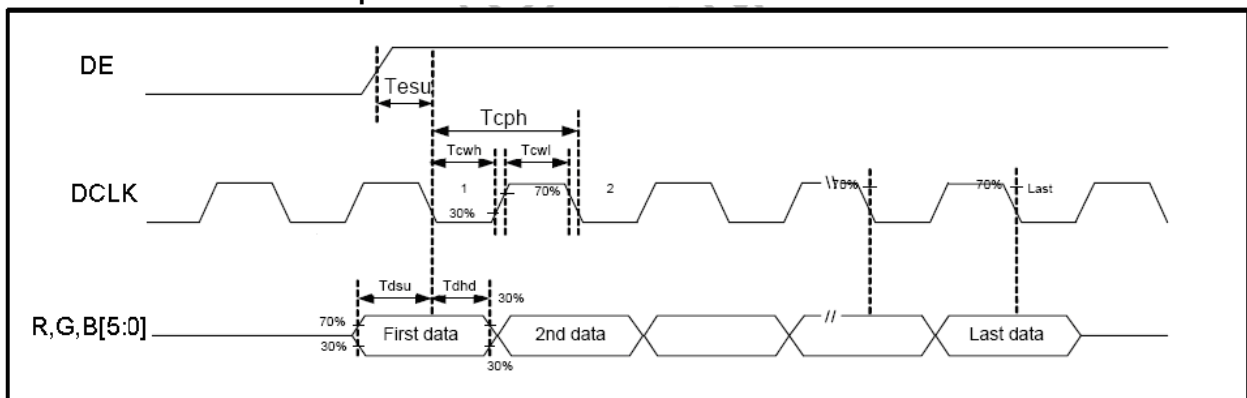
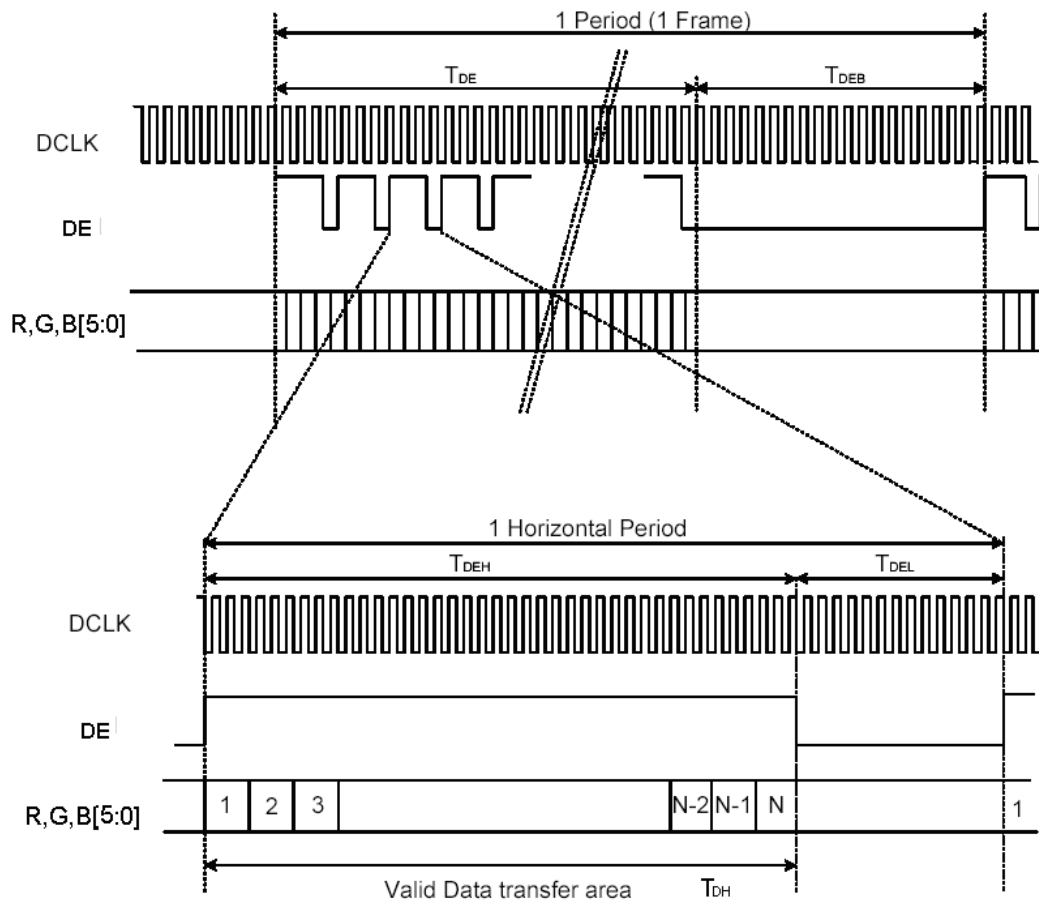
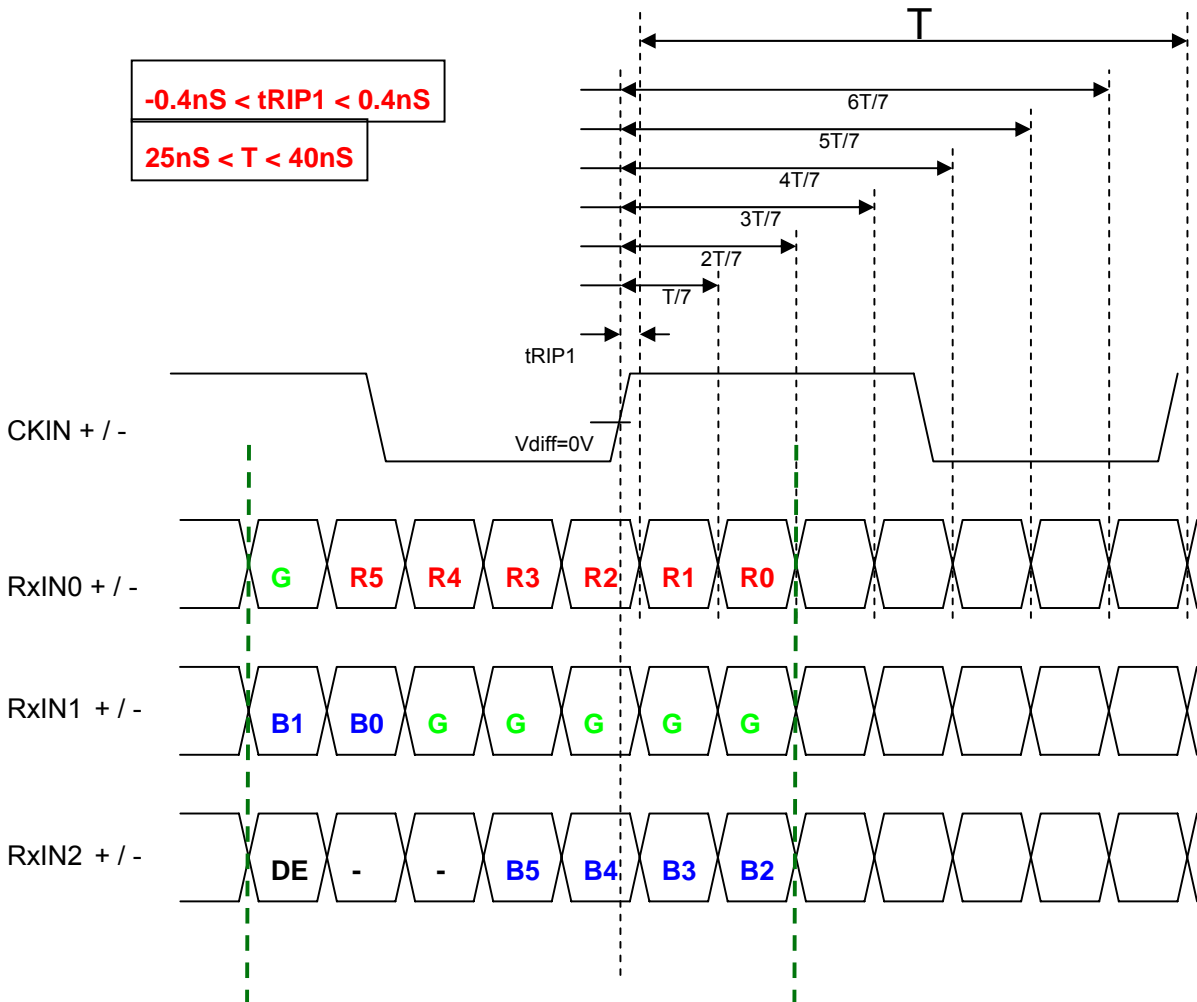

Figure 1 Clock and Data input waveforms.



### 7.2.2 LVDS Timing Chart



### 7.3 Color Data Input Assignment

		Data Signal																	
		Red					Green					Blue							
Color		R5	R4	R3	R2	R1	R0	G5	G4	G3	G2	G1	G0	B5	B4	B3	B2	B1	B0
Basic Colors	Black	0	0	0	0	0	0	0	0	0	0	0	0	0	0	0	0	0	0
	Red	1	1	1	1	1	1	0	0	0	0	0	0	0	0	0	0	0	0
	Green	0	0	0	0	0	0	1	1	1	1	1	1	0	0	0	0	0	0
	Blue	0	0	0	0	0	0	0	0	0	0	0	0	1	1	1	1	1	1
	Cyan	0	0	0	0	0	0	1	1	1	1	1	1	1	1	1	1	1	1
	Magenta	1	1	1	1	1	1	0	0	0	0	0	0	1	1	1	1	1	1
	Yellow	1	1	1	1	1	1	1	1	1	1	1	1	0	0	0	0	0	0
	White	1	1	1	1	1	1	1	1	1	1	1	1	1	1	1	1	1	1
Gray Scale of Red	Red(0) / Dark	0	0	0	0	0	0	0	0	0	0	0	0	0	0	0	0	0	0
	Red(1)	0	0	0	0	0	1	0	0	0	0	0	0	0	0	0	0	0	0
	Red(2)	0	0	0	0	1	0	0	0	0	0	0	0	0	0	0	0	0	0
	:	:	:	:	:	:	:	:	:	:	:	:	:	:	:	:	:	:	:
	:	:	:	:	:	:	:	:	:	:	:	:	:	:	:	:	:	:	:
	Red(61)	1	1	1	1	0	1	0	0	0	0	0	0	0	0	0	0	0	0
	Red(62)	1	1	1	1	1	0	0	0	0	0	0	0	0	0	0	0	0	0
	Red(63)	1	1	1	1	1	1	0	0	0	0	0	0	0	0	0	0	0	0
Gray Scale of Green	Green(0) / Dark	0	0	0	0	0	0	0	0	0	0	0	0	0	0	0	0	0	0
	Green(1)	0	0	0	0	0	0	0	0	0	0	0	1	0	0	0	0	0	0
	Green(2)	0	0	0	0	0	0	0	0	0	0	1	0	0	0	0	0	0	0
	:	:	:	:	:	:	:	:	:	:	:	:	:	:	:	:	:	:	:
	:	:	:	:	:	:	:	:	:	:	:	:	:	:	:	:	:	:	:
	Green(61)	0	0	0	0	0	0	1	1	1	1	0	1	0	0	0	0	0	0
	Green(62)	0	0	0	0	0	0	1	1	1	1	1	0	0	0	0	0	0	0
	Green(63)	0	0	0	0	0	0	1	1	1	1	1	1	0	0	0	0	0	0
Gray Scale of Blue	Blue(0) / Dark	0	0	0	0	0	0	0	0	0	0	0	0	0	0	0	0	0	0
	Blue (1)	0	0	0	0	0	0	0	0	0	0	0	0	0	0	0	0	0	1
	Blue (2)	0	0	0	0	0	0	0	0	0	0	0	0	0	0	0	0	1	0
	:	:	:	:	:	:	:	:	:	:	:	:	:	:	:	:	:	:	:
	:	:	:	:	:	:	:	:	:	:	:	:	:	:	:	:	:	:	:
	Blue (61)	0	0	0	0	0	0	0	0	0	0	0	0	1	1	1	1	0	1
	Blue (62)	0	0	0	0	0	0	0	0	0	0	0	0	1	1	1	1	1	0
	Blue (63)	0	0	0	0	0	0	0	0	0	0	0	0	1	1	1	1	1	1

### Correspondence between Data and Display Position

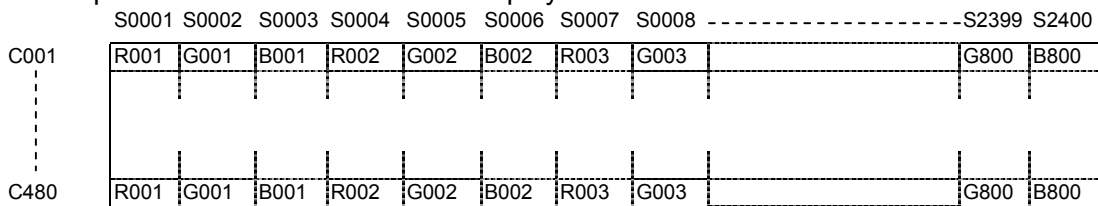

### 8. OPTICAL CHARACTERISTIC

Parameter		Symbol	Condition	MIN.	TYP.	MAX.	Unit	Remarks
Viewing Angle	Horizontal	$\theta_{x+}$	Center CR $\geq$ 10	65	70	--	deg	Note 1,4
		$\theta_{x-}$		65	70	--		
	Vertical	$\theta_{y+}$		55	60	--		
		$\theta_{y-}$		55	60	--		
Contrast Ratio		CR	at optimized viewing angle	250	400	--		Note 1,3
Response time	Rise	Tr	Center $\theta_x=\theta_y=0^\circ$	-	5	10	ms	Note 1,6
	Fall	Tf		-	11	16	ms	
Uniformity		B-uni	$\theta_x=\theta_y=0^\circ$	70	80	--	%	Note 1,5
Brightness		L	$\theta_x=\theta_y=0^\circ$	400	500	--	cd/m <sup>2</sup>	Note 1,2
Chromaticity		$x_W$	Center $\theta_x=\theta_y=0^\circ$	0.26	0.31	0.36		Note 1,7
		$y_W$		0.28	0.33	0.38		
		$x_R$		0.52	0.57	0.62		
		$y_R$		0.31	0.36	0.41		
		$x_G$		0.30	0.35	0.40		
		$y_G$		0.53	0.58	0.63		
		$x_B$		0.10	0.15	0.20		
		$y_B$		0.09	0.14	0.19		
Image sticking		tis	2 hours			2	Sec	Note 8

The following optical specifications shall be measured in a darkroom or equivalent state (ambient luminance  $\leq 1$  lux, and at room temperature). The operation temperature is  $25^\circ\text{C} \pm 2^\circ\text{C}$ . The measurement method is shown in Note1.

Note1: The method of optical measurement:

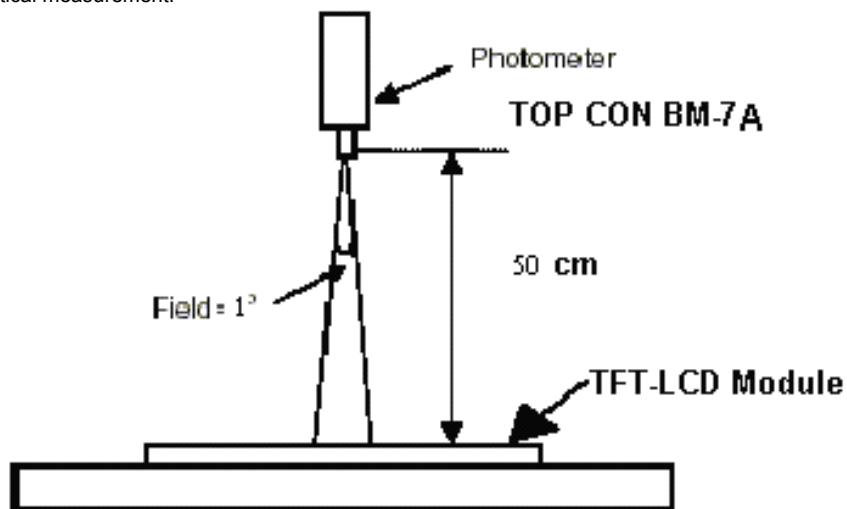



Note2: Measured at the center area of the panel and at the viewing angle of the  $\theta_x = \theta_y = 0^\circ$

Note3: Definition of Contrast Ratio (CR):

$$CR = \frac{\text{Luminance with all pixels in white state}}{\text{Luminance with all pixels in Black state}}$$

Note4: Definition of Viewing Angle

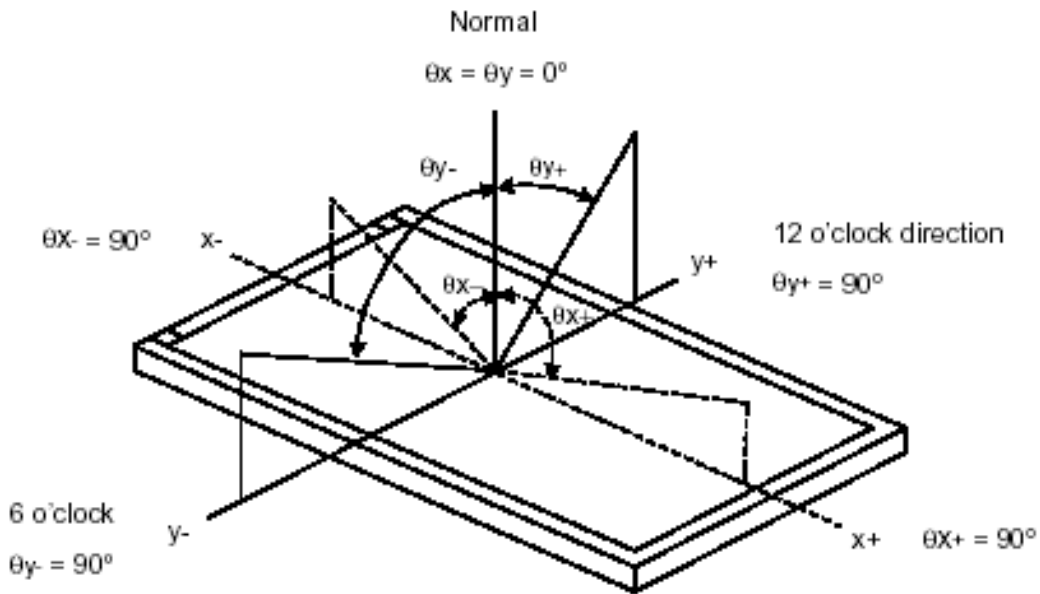

Note 5: Definition of Brightness Uniformity (B-uni):

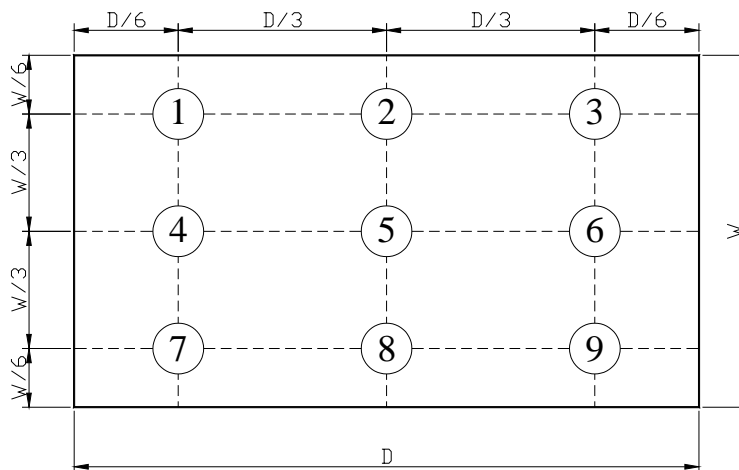

$$B\text{-uni} = \frac{\text{Minimum luminance of 9 points}}{\text{Maximum luminance of 9 points}} \quad (\text{Note 5}).$$

Note6: Definition of Response Time:

The Response Time is set initially by defining the "Rising Time ( $T_r$ )" and the "Falling Time ( $T_f$ )" respectively.  $T_r$  and  $T_f$  are defined as following figure.

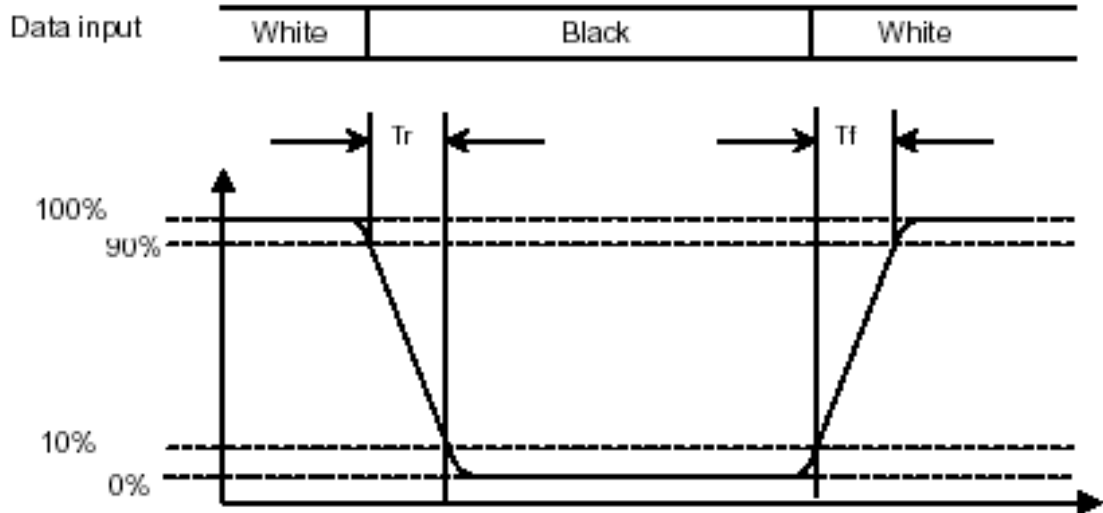

Note 7: Definition of Chromaticity:

The color coordinates  $(x_w, y_w)$ ,  $(x_r, y_r)$ ,  $(x_g, y_g)$ , and  $(x_b, y_b)$  are obtained with all pixels in the viewing field at white, red, green, and blue states, respectively.

Note 8: Definition of Image sticking (tis):

Continuously display the test pattern shown in the figure below for 2 hours. Then display a completely white screen. The previous image shall not persist more than 2 sec at 25 °C

**Image sticking pattern**

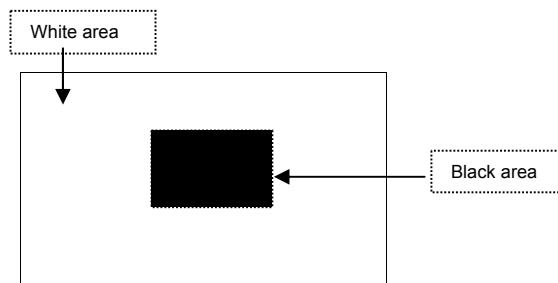

## 9. PIN CONNECTIONS

### 9.1TFT PIN Connections

Pin No	Symbol	Function	Remark
1	VCC	power supply for Digital Circuit	
2	VCC	power supply for Digital Circuit	
3	GND	Ground	
4	GND	Ground	
5	RxIN0-	Differential Data Input ,CH0(Negative)	
6	RxIN0+	Differential Data Input ,CH0(Positive)	
7	GND	Ground	
8	RxIN1-	Differential Data Input ,CH1(Negative)	
9	RxIN1+	Differential Data Input ,CH1(Positive)	
10	GND	Ground	
11	RxIN2-	Differential Data Input ,CH2(Negative)	
12	RxIN2+	Differential Data Input ,CH2(Positive)	
13	GND	Ground	
14	CKIN-	Differential Clock Input (Negative)	
15	CKIN+	Differential Clock Input (Positive)	
16	GND	Ground	
17	VDD	Power Supply for LED Driver Circuit	
18	VDD	Power Supply for LED Driver Circuit	
19	GND	Ground	
20	ADJ	Brightness control for LED B/L	

Remarks :

- 1) ADJ is brightness control Pin. The larger of the pulse duty is, the higher of the brightness.
- 2) ADJ signal is 0~3.3V.Operation frequency is 20KHz
- 3) GND PIN must be grounding, can not be floating.

Remarks:

Power Signal sequence:

$t1 \leq 10\text{ms}$  ;  $1 \text{ sec} \leq t5$

$50\text{ms} \leq t2$  ;  $200\text{ms} \leq t6$

$0 < t3 \leq 50\text{ms}$  ;  $200\text{ms} \leq t7$

$0 < t4 \leq 10\text{ms}$

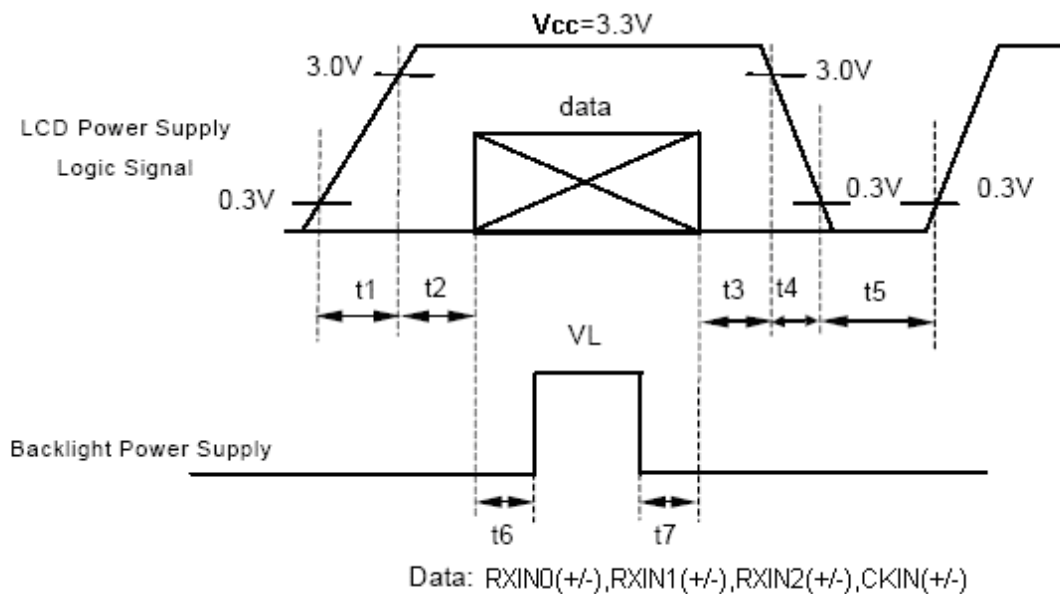

VCC-dip condition:

(1)  $2.7 \text{ V} \leq VCC < 3.0\text{V}$ ,  $t_d \leq 10 \text{ ms}$

(2)  $VCC > 3.0\text{V}$ , VCC-dip condition should be the same with VCC-turn-on condition.

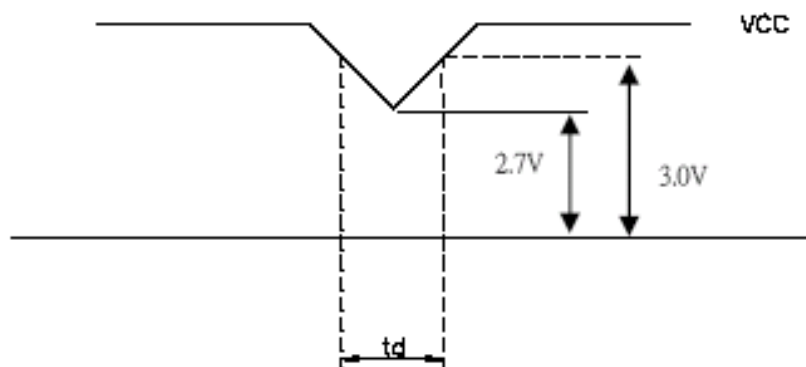

### 10. BLOCK DIAGRAM

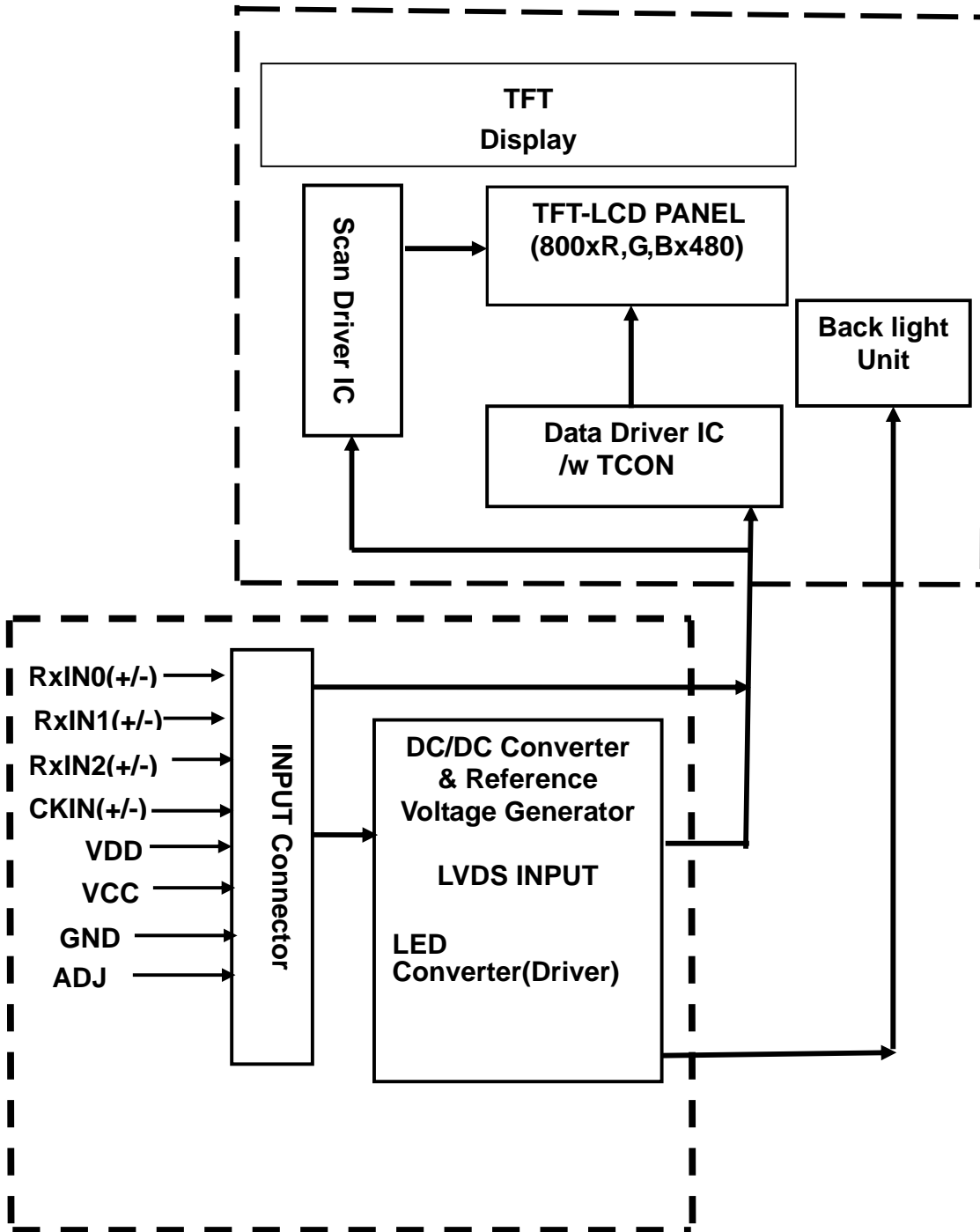

## 11. QUALITY ASSURANCE

### 11.1 Test Condition

#### 11.1.1 Temperature and Humidity(Ambient Temperature)

Temperature :  $25 \pm 5^{\circ}\text{C}$

Humidity :  $65 \pm 5\%$

#### 11.1.2 Operation

Unless specified otherwise, test will be conducted under function state.

#### 11.1.3 Container

Unless specified otherwise, vibration test will be conducted to the product itself without putting it in a container.

#### 11.1.4 Test Frequency

In case of related to deterioration such as shock test. It will be conducted only once.

#### 11.1.5 Test Method

Reliability Test Item & Level		Test Level	Remark
No.	Test Item		
1	High Temperature Storage Test	T=80 ,240hrs	IEC68-2-2
2	Low Temperature Storage Test	T=-30 ,240hrs	IEC68-2-1
3	High Temperature Operation Test	T=70 ,240hrs	IEC68-2-2
4	Low Temperature Operation Test	T=-20 ,240hrs	IEC68-2-1
5	High temperature and high humidity operation test	T=60 ,90%RH,240H	IEC68-2-3
6	Thermal cycling storage test (No operation)	-30 ----25 -----80 ,200Cycle 30min 5min 30min	IEC68-2-14
7	vibration test (No operation)	Frequency:10~55HZ Amplitude:1.5mm Sweep time:11min Test period:6Cycles for each direction of X,Y,Z	IEC68-2-6
8	Shock Test (No operation)	100G,6ms,Direction:±X±Y±Z Cycle:3times	IEC68-2-27
9	Drop test	Height :60cm 1 conner,3edges,6surfaces	IEC68-2-32
10	ESD Test	State: operating Location: LCM/TP surface Condition:150pf 330Ω Contact +/- 8kV Air +/-15kV Criteria: Class C	IEC61000-4-2

## 11.2 Inspection condition

### 11.2.1 Inspection conditions

11.2.1.1 Inspection Distance:  $35 \pm 5$  cm

11.2.1.2 View Angle:

- ( 1 ) Inspection under operating condition :  $\pm 5^\circ$
- ( 2 ) Inspection under non-operating condition :  $\pm 45^\circ$

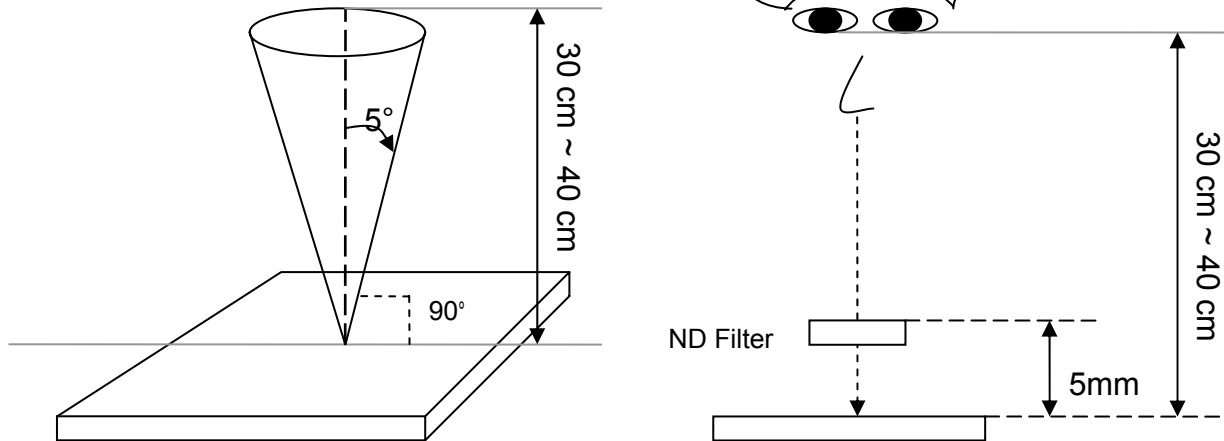

11.2.1.3 Environment conditions:

Ambient Temperature :		25±5
Ambient Humidity :		65±5%
Ambient Illumination	Cosmetic Inspection	More than 600lux
	Functional Inspection	300 ~ 800lux

### 11.2.2 Definition of applicable Zones



## 11.2.3 Inspection Parameters

No.	Parameter	Criteria																		
1	Operating	Display function: No Display malfunction (Major)																		
		Contrast ratio (Black, White): Does not meet specified range in the spec. (Major) (Note:3)																		
		Line Defect: No obvious Vertical and Horizontal line defect in bright, dark and colored. (Major) (Note:1)																		
		Point Defect (Red, green, blue, dark): Active area $\leq 8$ dots (Minor)(Note:1)																		
		<table border="1"> <thead> <tr> <th>Item</th> <th>Acceptable number</th> <th>Total</th> <th>Class Of Defects</th> <th>AQL Level</th> </tr> </thead> <tbody> <tr> <td>Bright</td> <td>4</td> <td rowspan="2">8</td> <td rowspan="4">Minor</td> <td rowspan="4">1.5</td> </tr> <tr> <td>Dark</td> <td>4</td> </tr> <tr> <td>Adjacent Bright</td> <td>1</td> <td>1</td> </tr> <tr> <td>Adjacent Dark</td> <td>1</td> <td>1</td> </tr> </tbody> </table>	Item	Acceptable number	Total	Class Of Defects	AQL Level	Bright	4	8	Minor	1.5	Dark	4	Adjacent Bright	1	1	Adjacent Dark	1	1
		Item	Acceptable number	Total	Class Of Defects	AQL Level														
		Bright	4	8	Minor	1.5														
		Dark	4																	
		Adjacent Bright	1	1																
		Adjacent Dark	1	1																
Non-uniformity: Visible through 2%ND filter white, R, G, B and gray 50%pattern. (Minor)																				
Foreign material in Black or White spots shape ( $W > 1/4L$ ) (Note: 5)																				
<table border="1"> <thead> <tr> <th>Dimension</th> <th>Acceptable number</th> <th>Class Of Defects</th> <th>AQL Level</th> </tr> </thead> <tbody> <tr> <td><math>D \leq 0.3</math></td> <td>*</td> <td rowspan="3">Minor</td> <td rowspan="3">1.5</td> </tr> <tr> <td><math>0.3 &lt; D \leq 0.5</math></td> <td>4</td> </tr> <tr> <td><math>D &gt; 0.5</math></td> <td>0</td> </tr> </tbody> </table>	Dimension	Acceptable number	Class Of Defects	AQL Level	$D \leq 0.3$	*	Minor	1.5	$0.3 < D \leq 0.5$	4	$D > 0.5$	0								
Dimension	Acceptable number	Class Of Defects	AQL Level																	
$D \leq 0.3$	*	Minor	1.5																	
$0.3 < D \leq 0.5$	4																			
$D > 0.5$	0																			
$D = (\text{Long} + \text{Short}) / 2$ * : Disregard																				
Foreign Material in Line or spiral shape ( $W \leq 1/4L$ ) (Note: 4)																				
<table border="1"> <thead> <tr> <th>Dimension</th> <th>Acceptable number</th> <th>Class Of Defects</th> <th>AQL Level</th> </tr> </thead> <tbody> <tr> <td><math>W &gt; 0.1\text{mm}, L &gt; 5\text{mm}</math></td> <td>0</td> <td rowspan="3">Minor</td> <td rowspan="3">1.5</td> </tr> <tr> <td><math>L \leq 5\text{mm}, 0.07\text{mm} &lt; W \leq 0.1\text{mm}</math></td> <td>4</td> </tr> <tr> <td><math>L \leq 5\text{mm}, W &lt; 0.07\text{mm}</math></td> <td>*</td> </tr> </tbody> </table>	Dimension	Acceptable number	Class Of Defects	AQL Level	$W > 0.1\text{mm}, L > 5\text{mm}$	0	Minor	1.5	$L \leq 5\text{mm}, 0.07\text{mm} < W \leq 0.1\text{mm}$	4	$L \leq 5\text{mm}, W < 0.07\text{mm}$	*								
Dimension	Acceptable number	Class Of Defects	AQL Level																	
$W > 0.1\text{mm}, L > 5\text{mm}$	0	Minor	1.5																	
$L \leq 5\text{mm}, 0.07\text{mm} < W \leq 0.1\text{mm}$	4																			
$L \leq 5\text{mm}, W < 0.07\text{mm}$	*																			
L : Length W : Width * : Disregard																				
2	External Inspection (non-operating)	Dimension: Outline (Major)																		
		Bezel appearance: uneven (Minor)																		
		Scratch on the Polarize & Touch Panel : (Note:2)																		
		<table border="1"> <thead> <tr> <th>Dimension</th> <th>Acceptable number</th> <th>Class Of Defects</th> <th>AQL Level</th> </tr> </thead> <tbody> <tr> <td><math>W &gt; 0.1\text{mm}, L &gt; 5\text{mm}</math></td> <td>0</td> <td rowspan="3">Minor</td> <td rowspan="3">1.5</td> </tr> <tr> <td><math>L \leq 5\text{mm}, 0.07\text{mm} &lt; W \leq 0.1\text{mm}</math></td> <td>4</td> </tr> <tr> <td><math>L \leq 5\text{mm}, W &lt; 0.07\text{mm}</math></td> <td>*</td> </tr> </tbody> </table>	Dimension	Acceptable number	Class Of Defects	AQL Level	$W > 0.1\text{mm}, L > 5\text{mm}$	0	Minor	1.5	$L \leq 5\text{mm}, 0.07\text{mm} < W \leq 0.1\text{mm}$	4	$L \leq 5\text{mm}, W < 0.07\text{mm}$	*						
		Dimension	Acceptable number	Class Of Defects	AQL Level															
		$W > 0.1\text{mm}, L > 5\text{mm}$	0	Minor	1.5															
		$L \leq 5\text{mm}, 0.07\text{mm} < W \leq 0.1\text{mm}$	4																	
		$L \leq 5\text{mm}, W < 0.07\text{mm}$	*																	
L : Length W : Width * : Disregard																				
Dent and spots shape on the polarize (Note:2): (Note: 5)																				
<table border="1"> <thead> <tr> <th>Dimension</th> <th>Acceptable number</th> <th>Class Of Defects</th> <th>AQL Level</th> </tr> </thead> <tbody> <tr> <td><math>D \leq 0.3</math></td> <td>*</td> <td rowspan="3">Minor</td> <td rowspan="3">1.5</td> </tr> <tr> <td><math>0.3 &lt; D \leq 0.5</math></td> <td>4</td> </tr> <tr> <td><math>D &gt; 0.5</math></td> <td>0</td> </tr> </tbody> </table>	Dimension	Acceptable number	Class Of Defects	AQL Level	$D \leq 0.3$	*	Minor	1.5	$0.3 < D \leq 0.5$	4	$D > 0.5$	0								
Dimension	Acceptable number	Class Of Defects	AQL Level																	
$D \leq 0.3$	*	Minor	1.5																	
$0.3 < D \leq 0.5$	4																			
$D > 0.5$	0																			
$D = (\text{Long} + \text{Short}) / 2$ * : Disregard																				



Class of defects		Definition	
	<b>Major</b>	AQL 0.65	It is a defect that is likely to result in failure or to reduce materially the usability of the product for the intended function.
	<b>Minor</b>	AQL 1.5	It is a defect that will not result in functioning problem with deviation classified.

Note:1.(a)Bright point defect is defined as point defect of R,G,B with area >1/2 pixel respectively  
 (b)Dark point defect is defined as visible in full white pattern.  
 (c)The point defect must under 2% ND Filter visible .

Note:2 The external inspection should be conducted at the distance 30± 5cm between the eyes of inspector and the panel .

Note:3 Luminance measurement for contrast ratio is at the distance 50± 5cm between the detective head and the panel with ambient luminance less than 1 lux. Contrast ratio is obtained at optimum view angle.

Note:4 W-Width in mm , L-length of Max.(L1,L2) in mm.

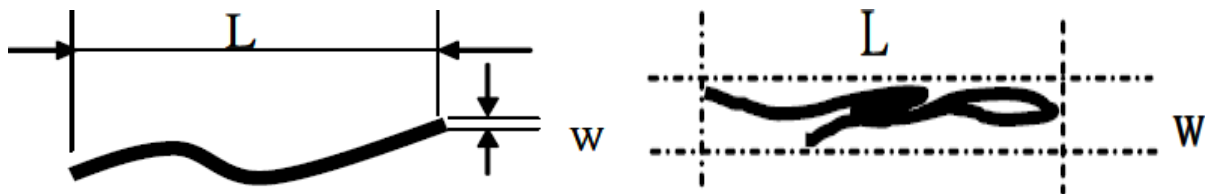

Note:5 Spot Foreign Material (W = L/4)

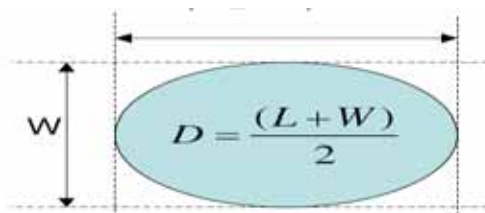

### 11.3 Sampling Condition

Unless otherwise agree in written, the sampling inspection shall be applied to the incoming inspection of customer.

Lot size: Quantity of shipment lot per model.

Sampling type: normal inspection, single sampling

Sampling table: MIL-STD-105E

Inspection level: Level II

## 12. LCM PRODUCT LABEL DEFINE

Product Label style:

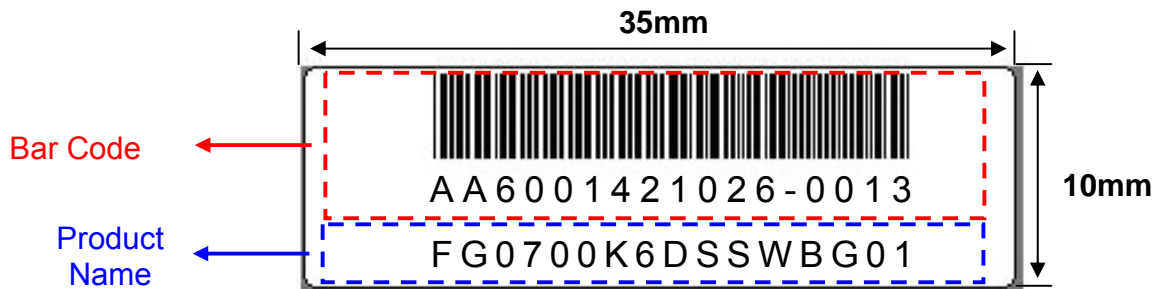

BarCode Define:

**A A 6 0014 2 10 26-0013**

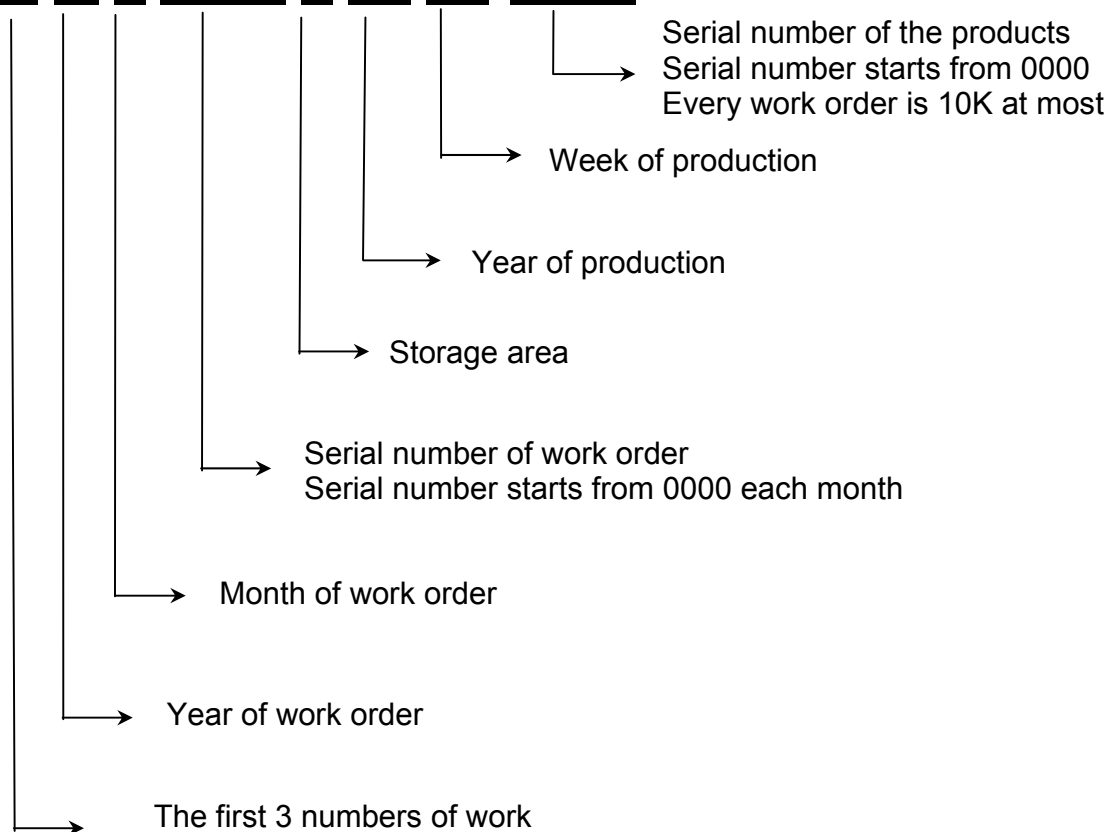

**Product Name Define:**

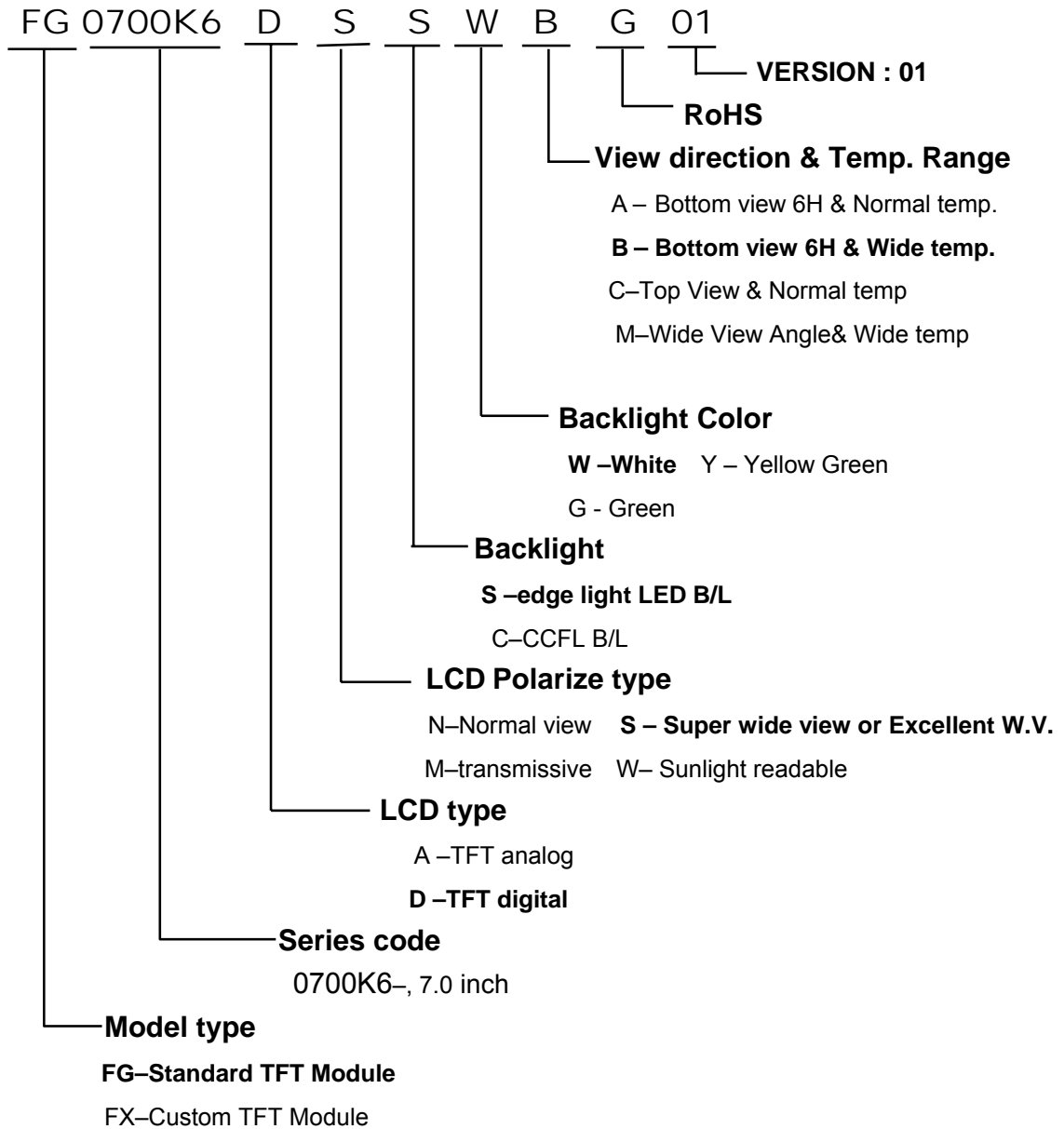

## 13. RECAUTIONS IN USE LCM

### 1. LIQUID CRYSTAL DISPLAY (LCD)

LCD is made up of glass, organic sealant, organic fluid, and polymer based polarizers. The following precautions should be taken when handling,

- (1). Keep the temperature within range of use and storage. Excessive temperature and humidity could cause polarization degradation, polarizer peel off or bubble.
- (2). Do not contact the exposed polarizers with anything harder than an HB pencil lead. To clean dust off the display surface, wipe gently with cotton, chamois or other soft material soaked in petroleum benzin.
- (3). Wipe off saliva or water drops immediately. Contact with water over a long period of time may cause polarizer deformation or color fading, while an active LCD with water condensation on its surface will cause corrosion of ITO electrodes.
- (4). Glass can be easily chipped or cracked from rough handling, especially at corners and edges.
- (5). Do not drive LCD with DC voltage.

### 2. Liquid Crystal Display Modules

#### 2.1 Mechanical Considerations

LCM are assembled and adjusted with a high degree of precision. Avoid excessive shocks and do not make any alterations or modifications. The following should be noted.

- (1). Do not tamper in any way with the tabs on the metal frame.
- (2). Do not modify the PCB by drilling extra holes, changing its outline, moving its components or modifying its pattern.
- (3). Do not touch the elastomer connector, especially insert an backlight panel (for example, EL).
- (4). When mounting a LCM make sure that the PCB is not under any stress such as bending or twisting. Elastomer contacts are very delicate and missing pixels could result from slight dislocation of any of the elements.
- (5). Avoid pressing on the metal bezel, otherwise the elastomer connector could be deformed and lose contact, resulting in missing pixels.

#### 2.2 Static Electricity

LCM contains CMOS LSI's and the same precaution for such devices should apply, namely

- (1). The operator should be grounded whenever he/she comes into contact with the module. Never touch any of the conductive parts such as the LSI pads, the copper leads on the PCB and the interface terminals with any parts of the human body.
- (2). The modules should be kept in antistatic bags or other containers resistant to static for storage.
- (3). Only properly grounded soldering irons should be used.
- (4). If an electric screwdriver is used, it should be well grounded and shielded from commutator sparks.

- (5) The normal static prevention measures should be observed for work clothes and working benches; for the latter conductive (rubber) mat is recommended.
- (6). Since dry air is inductive to statics, a relative humidity of 50-60% is recommended.

#### 2.3 Soldering

- (1). Solder only to the I/O terminals.
- (2). Use only soldering irons with proper grounding and no leakage.
- (3). Soldering temperature :  $280^{\circ}\text{C} \pm 10^{\circ}\text{C}$
- (4). Soldering time: 3 to 4 sec.
- (5). Use eutectic solder with resin flux fill.
- (6). If flux is used, the LCD surface should be covered to avoid flux spatters. Flux residue should be removed after wards.

#### 2.4 Operation

- (1). The viewing angle can be adjusted by varying the LCD driving voltage V0.
- (2). Driving voltage should be kept within specified range; excess voltage shortens display life.
- (3). Response time increases with decrease in temperature.
- (4). Display may turn black or dark blue at temperatures above its operational range; this is (however not pressing on the viewing area) may cause the segments to appear "fractured".
- (5). Mechanical disturbance during operation (such as pressing on the viewing area) may cause the segments to appear "fractured".

#### 2.5 Storage

If any fluid leaks out of a damaged glass cell, wash off any human part that comes into contact with soap and water. Never swallow the fluid. The toxicity is extremely low but caution should be exercised at all the time.

#### 2.6 Limited Warranty

Unless otherwise agreed between DATA IMAGE and customer, DATA IMAGE will replace or repair any of its LCD and LCM which is found to be defective electrically and visually when inspected in accordance with DATA IMAGE acceptance standards, for a period on one year from date of shipment. Confirmation of such date shall be based on freight documents. The warranty liability of DATA IMAGE is limited to repair and/or replacement on the terms set forth above. DATA IMAGE will not responsible for any subsequent or consequential events.

Confidential Document  
**14. OUTLINE DRAWING**

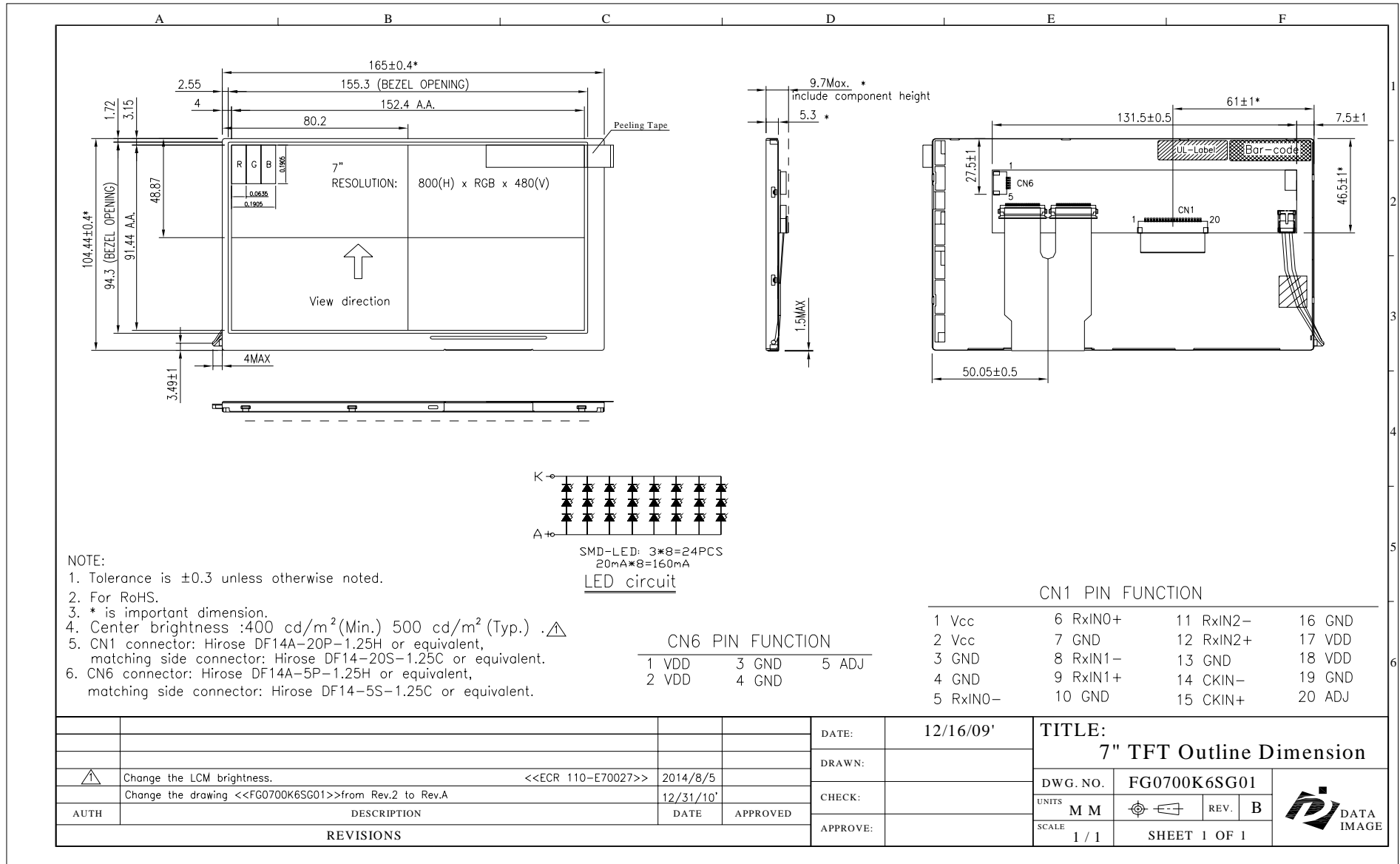

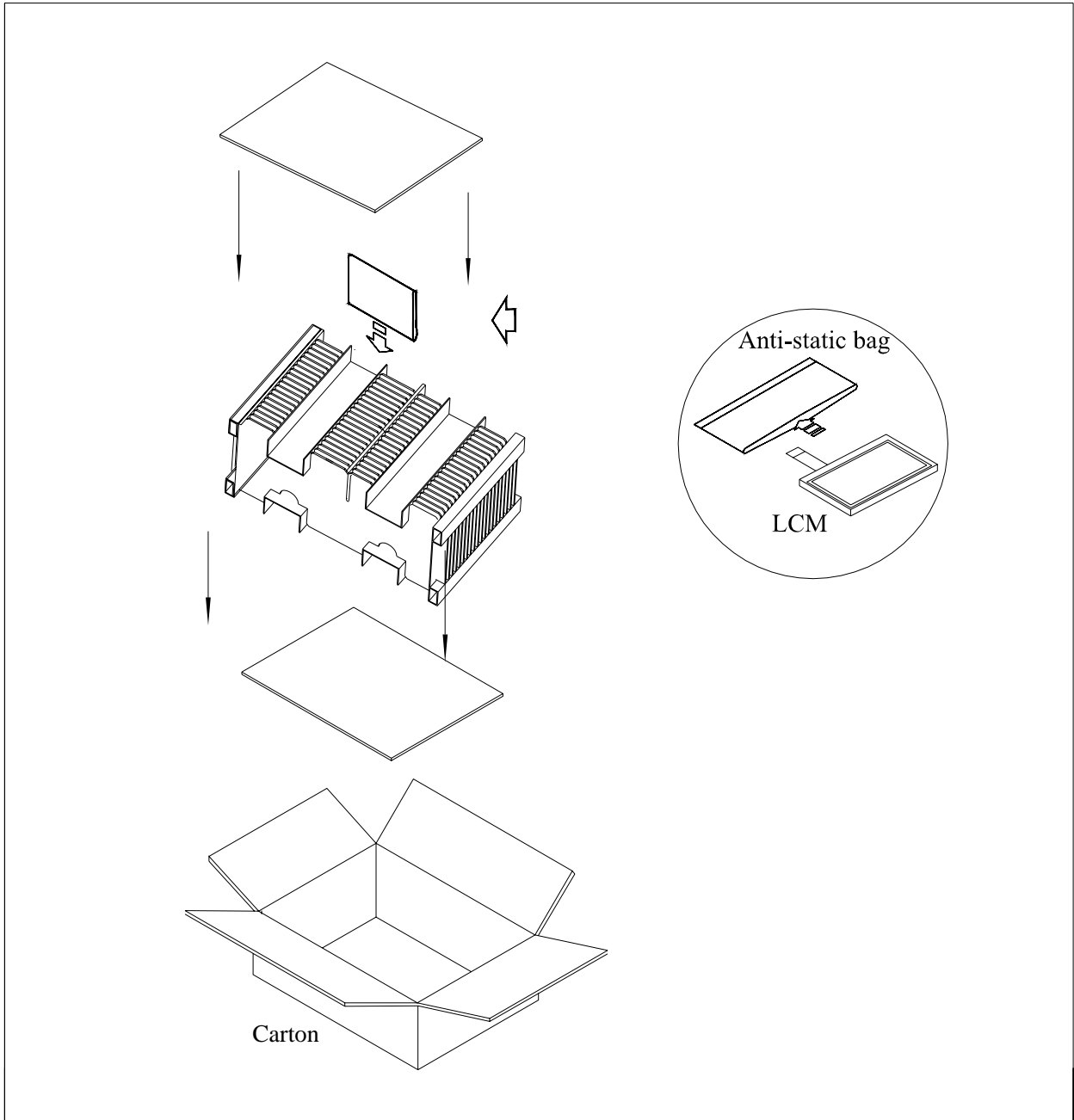
**15. PACKAGE INFORMATION**

Item	Size(L*W*H)	Quantity	Note
Master Carton	482*282*279	1	
Quantity Per Master Carton		30	
N . W	4.0 (kg)	G . W	5.6 (kg)