



DATA IMAGE CORPORATION

TFT Module Specification Preliminary

ITEM NO.: FG0700I0DSSWAGT1

Table of Contents

- 1. COVER & CONTENTS 1
- 2. RECORD OF REVISION 2
- 3. APPLICATION..... 3
- 4. GENERAL SPECIFICATIONS 3
- 5. ABSOLUTE MAXIMUM RATINGS 3
- 6. ELECTRICAL CHARACTERISTICS 3
- 7. DC CHARATERISTICS 5
- 8. AC CHARATERISTICS 7
- 9. OPTICAL CHARACTERISTIC 10
- 10. PIN CONNECTIONS 13
- 11. BLOCK DIAGRAM 15
- 12. TOUCH PANEL CHARACTERISTICS 16
- 13. QUALITY ASSURANCE 17
- 14. LOT NUMBERING SYSTEM 18
- 15. LCM NUMBERING SYSTEM 18
- 16. PRECAUTIONS IN USE LCM 19
- 17. OUTLINE DRAWING 20
- 18. PACKAGE INFORMATION 21

Customer Companies	R&D Dept.	Q.C. Dept.	Eng. Dept.	Prod. Dept.
	ALEX	ERIC	PAUL	HELEN
Approved by	Version:	Issued Date:	Sheet Code:	Total Pages:
	1	2009/3/11		21



2. RECORD OF REVISION

Rev	Date	Item	Page	Comment
1	11/MAR/09			Initial PRELIMINARY

3. APPLICATION

DVD player, Car TV, UMPC, POS

4. GENERAL SPECIFICATIONS

Parameter	Specifications	Unit
Screen Size	7 (diagonal)	inch
Display Format	800(H) x (R,G,B) x 480(V)	dot
Active Area	152.4(H) x 91.44(V)	mm
Pixel size	190.5 (H) x 190.5 (V)	um
Pixel Configuration	RGB Vertical Stripe	
Outline Dimension	165(W) x 104(H) x 6.7 (D)	mm
Surface treatment	Anti-glare	
Back-light	LED	
Display mode	Normally white	
Weight	160	g
View Angle direction	6 o'clock	

5. ABSOLUTE MAXIMUM RATINGS

Parameter	Symbol	MIN.	MAX.	Unit	Remark
Digital Power Voltage	VCC	-0.5	5	V	Ta=25°C
Analog Power Voltage	AVDD	6.5	13.5	V	
Gamma Voltage	V1~V5	0.4AVDD	AVDD-0.1	V	
Gamma Voltage	V6~V10	0.1	0.6AVDD	V	
Gate On Voltage	VGH	7	VGL+40	V	
Gate Off Voltage	VGL	-20	-5	V	
Operating temperature	Top	-10	60	°C	Module surface*
Storage temperature	Tst	-30	+70	°C	-

6. ELECTRICAL CHARACTERISTICS

6.1 Operating Conditions

Ta=25°C

Parameter	Symbol	MIN.	Typ.	MAX.	Unit	Remark
Digital Power Voltage	VCC	3.0	3.3	3.6	V	1,2
Analog Power Voltage	AVDD	11.5	12	12.5	V	
Gate On Power Voltage	VGH	17	18	19	V	1,2
Gate Off Power Voltage	VGL	-8	-7	-6	V	1,2
Gamma Power Voltage	VCOM	-	3.6	-		
Input H/L level voltage	V _{IH}	0.7V _{cc}	--	V _{cc}	V	
	V _{IL}	0	--	0.3V _{cc}	V	

1) When power on :VCC→VGL→VGH

2) When power off : VGH→VGL →VCC

6.2 Backlight Driving Consumption

Ta= 25 °C

Parameter	Symbol	Min.	Typ.	Max.	Unit	Remark
VLED voltage	V_L	--	9.9	--	V	
LED current	I_L	--	180	250	mA	Note1:
LED life time		(10000)	--	--	hr	Note2

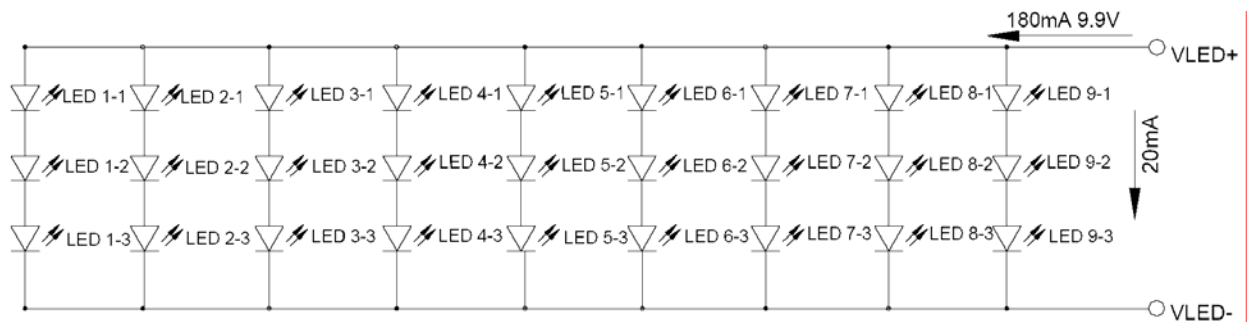

Note 1 : There are 9 Groups LED shown as below , VLED=9.9V (min.).

Note 2 : Brightness to be decreased to 50% of the initial value.

7. DC CHARACTERISTICS

7.1 For the digital circuit

Parameter	Symbol	Rating			Unit	Condition
		min	typ	max		
Supply Voltage	V _{CC}	2.7	3.3	3.6	V	Digital Power
Low Level Input Voltage	V _{IL}	0	--	0.3V _{CC}	V	For the Digital circuit
High Level Input Voltage	V _{IH}	0.7V _{CC}		V _{CC}	V	For the Digital circuit
High Level Output Voltage	V _{OH}	V _{CC} -0.4	--	--	V	DIO1,DIO2, IOL =1mA
Low Level Output Voltage	V _{OL}	GND	--	GND+4	V	DIO1,DIO2, IOL =1mA
Input Leakage Current	I _I	--	--	±1	mA	For the Digital circuit
Digital Stand-by Current	I _{ST}	--	10	50	mA	All operating circuit
Digital Operating Current	V _{CC}	--	1.31	1.6	V	All operating circuit F _{CLK} =40MHz, F _{LD} =50MHz, V _{CC} =3.3 V in black pattern
Pull low/high resister	R _I	150	300	--		Digital signal

7.2 For the analog circuit

Parameter	Symbol	Rating			Unit	Condition
		Min.	Typ.	Max.		
Supply Voltage	AVDD	11.5	12	12.5	V	For the analog circuit power
Input level of $V_{r1} \sim V_{r7}$	V_{REF}	0.4AVDD	--	AVDD-0.1	V	Gamma correction voltage
Input level of $V_{r8} \sim V_{r14}$	V_{REF}	0.1	--	0.6AVDD	V	Gamma correction voltage
Output Voltage deviation	V_{OD}	--	--	± 20	mV	
Voltage Output Offset Between Chips	V_{OC}	--	--	± 15	mV	
Dynamics Range of Output	V_{DR}	0.1	--	AVDD-0.1	V	OUT~OUT 480
Sinking Current of Output	I_{OL}	-80	--	-	μA	OUT1~OUT480, $V_o=0.1V$ v.s. 1.0V AVDD=10V
Driving Current of Output	I_{OH}	-80	--	-	μA	OUT1~OUT480, $V_o=9.9V$ v.s. 9V AVDD=10V
Impedence of Gamma Correction	R_i	0.8* Rn	1.1*Rn	1.4*Rn		Rn: Internal gamma resistor
Analog Stand-by Current	I_{SC}	--	2.59	3.0	mA	No load, AVDD=8.4V and all operation is stopped.
Analog Operating Current	I_{OC}	--	16.08	18.0	mA	$F_{CLK} = 40MHz$, $F_{LD} = 50MHz$, AVDD =8.4V, $V_{r1} =8V$, $V_{r14} =0.4V$ in black pattern

8. AC CHARACTERISTICS

(TA =25 ,VCC= 3V, AVDD=8.4V, AVSS=GND=0V)

Parameter	Symbol	Rating			Unit	Condition
		Min.	Typ.	Max.		
CLK frequency	Fclk		40	47	MHz	-
CLK pulse width	Tcw	6	-	-	ns	-
Data set-up time	Tsu	4	-	-	ns	D00~D55,REV and DIO1/2 to CLK
Data hold time	Thd	2	-	-	ns	D00~D55,REV and DIO1/2 to CLK
Propagation delay of DIO 2/1	Tphl	6	10	15	ns	CL=25pF(Output)
Time that the last data to LD	Tld	1	-	-	Tcph	-
Pulse width of LD	Twid	2	-	-	Tcph	-
Time that LD to DIO1/2	Tlds	5	-	-	Tcph	-
POL set-up time	Tpsu	6	-	-	ns	POL to LD
POL hold time	Tphd	6	-	-	ns	POL to LD
Output stable time	Tst	-	-	12	us	10% or 90% target voltage, CL=60pF, R=2K

Timing diagram 1 (Default CHNSL1=H, CHNSL0=H)
EDGSL= L or open

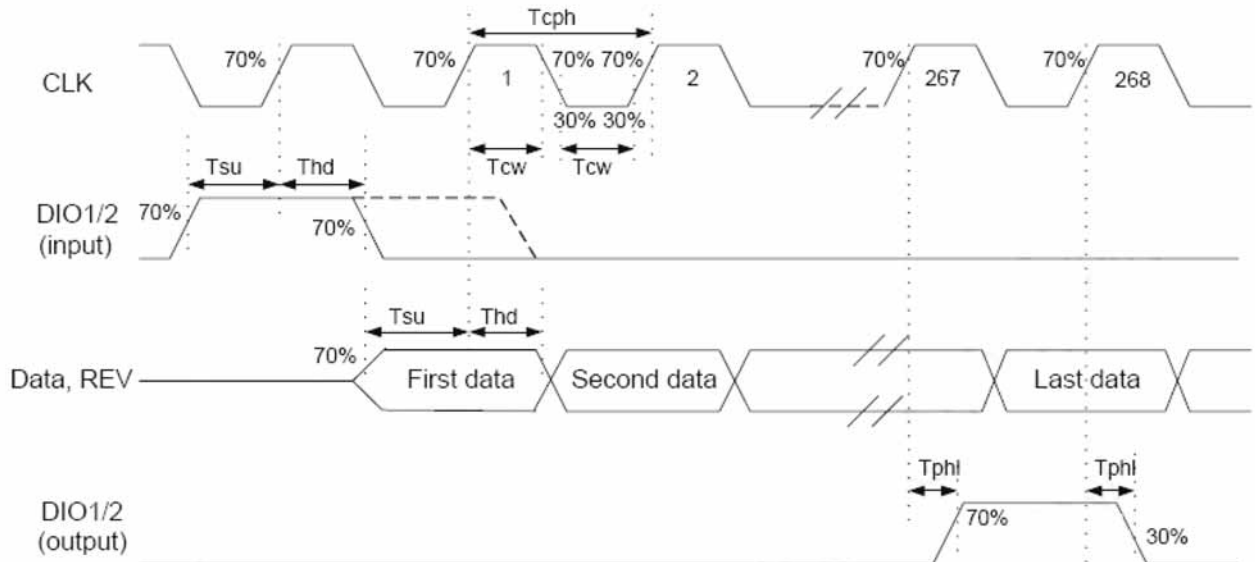

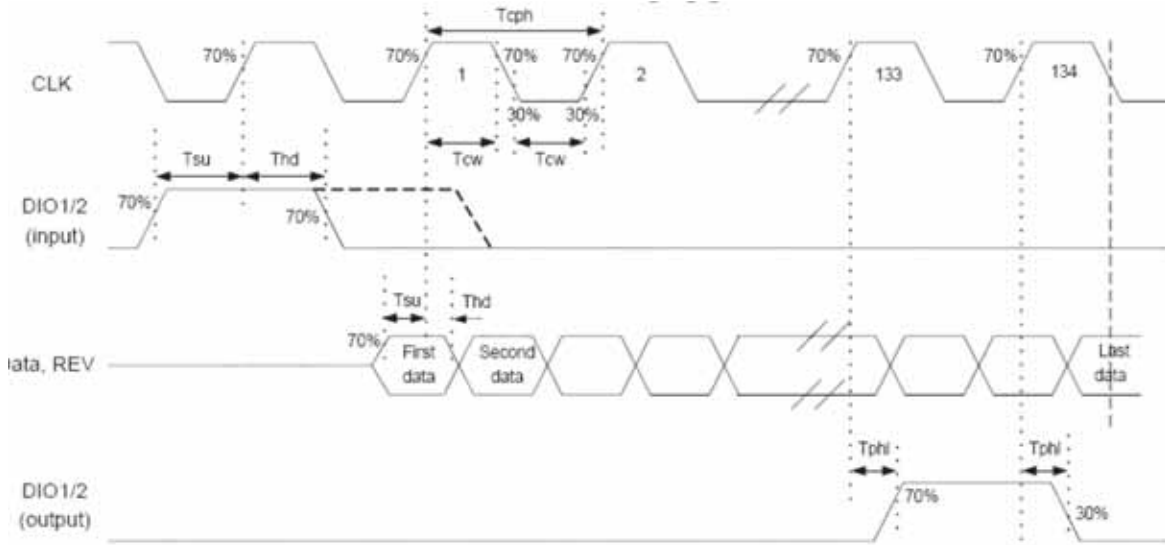
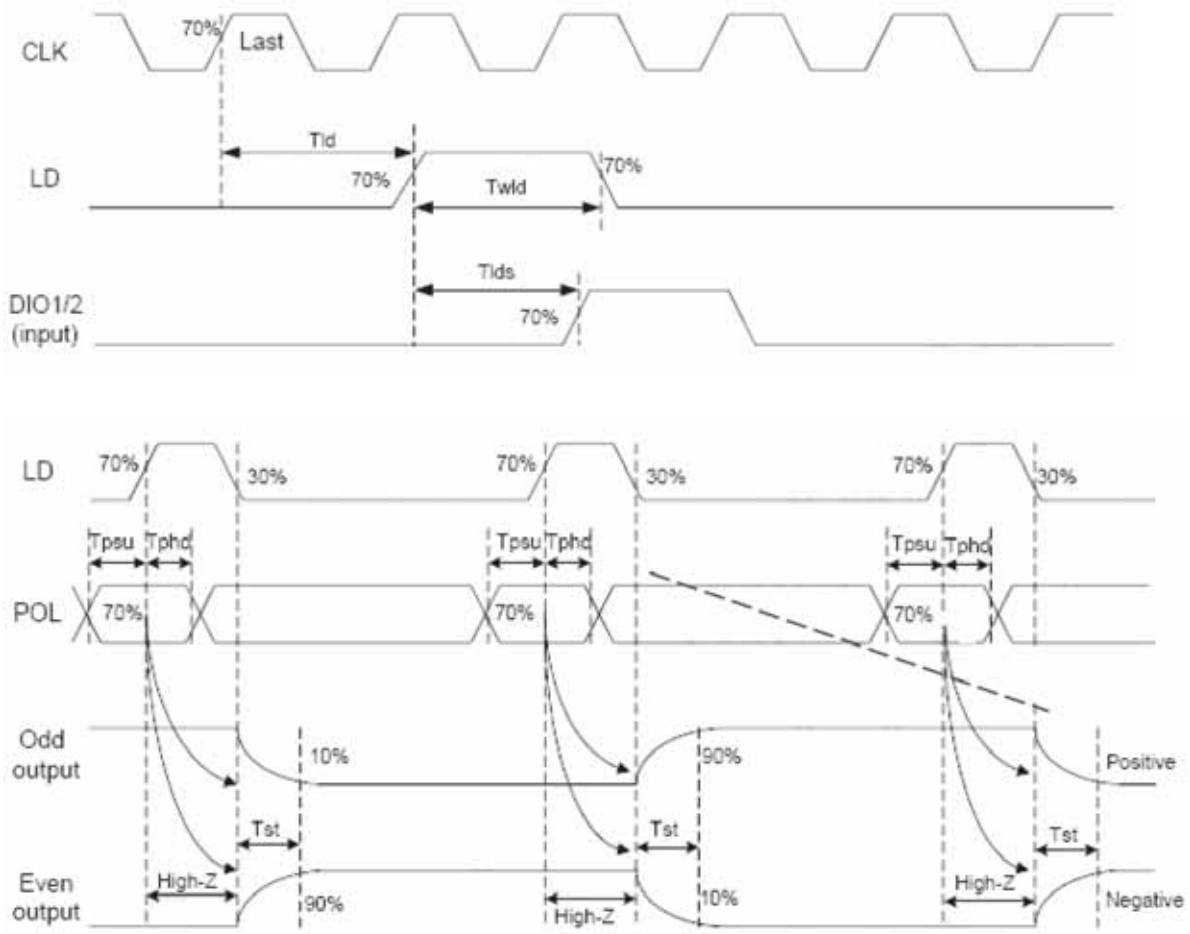
EDGSL= H

Timing diagram 2

8.1 Gate Driver Timing Chart

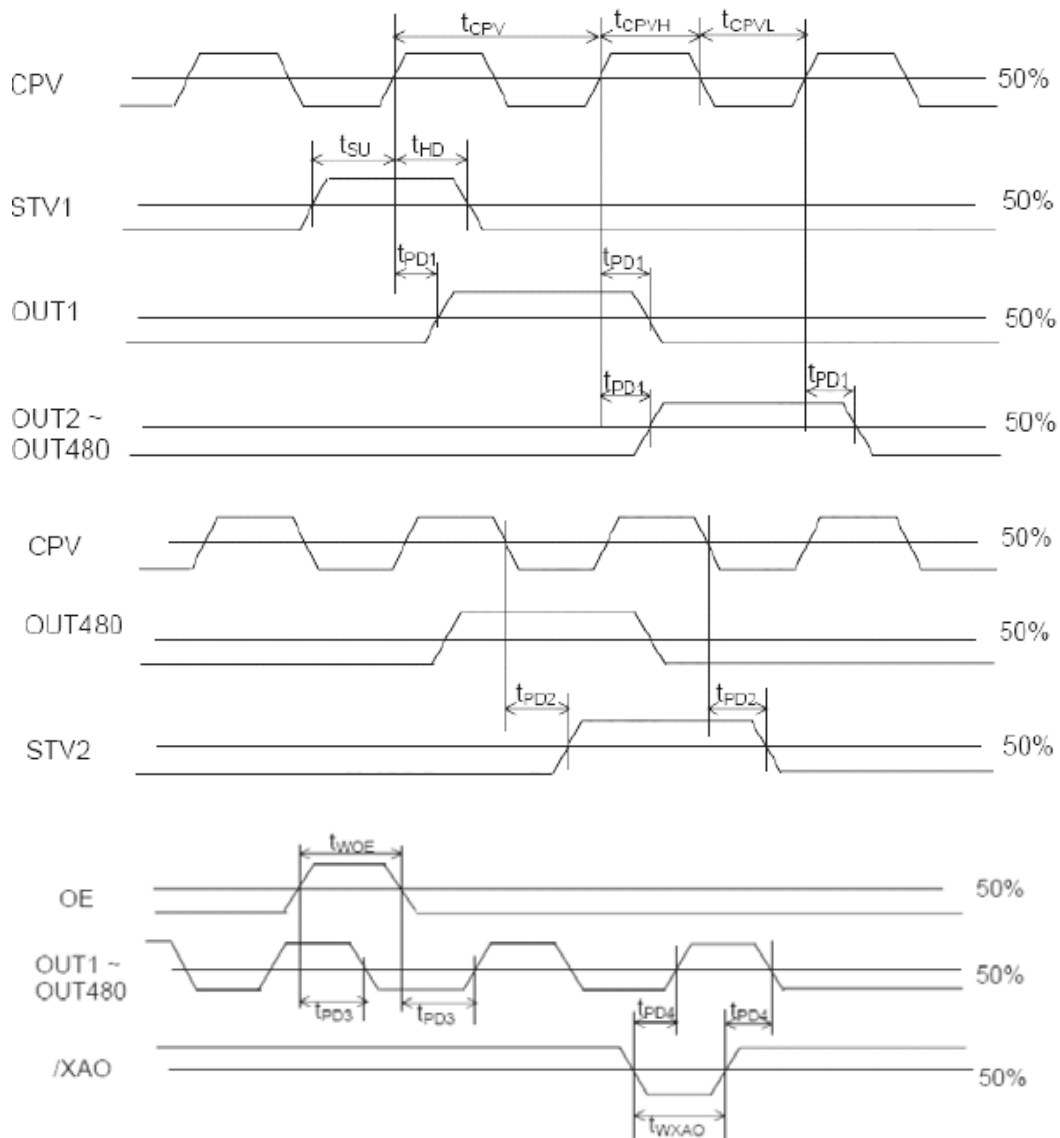
Parameter	Symbol	Condition	Spec		Unit
			Min.	Max.	
CPV period	t_{CP}	--	5	--	μs
CPV pulse width	t_{CPVH}, t_{CPVL}	50% duty cycle	2.5	--	
OE pulse width	t_{WO}	--	1	--	
/XAO pulse width	t_{WXA}	--	10	--	ns
Data setup time	t_s	--	700	--	
Data hold time	t_H	--	700	--	
CPV to output delay time	t_{PD}	$CL=300\text{pF}$	--	1000	
Start pulse output delay time	t_{PD2}	$CL=30\text{pF}$	--	800	
OE to output delay time	t_{PD}	$CL=300\text{pF}$	--	800	
/XAO to output delay time	t_{PD}	$CL=300\text{pF}$	--	10000	



9. OPTICAL CHARACTERISTIC

9.1. Specification:

Parameter		Symbol	Condition	MIN.	TYP.	MAX.	Unit	Remarks
Viewing Angle	Horizontal	θ_R	Center $CR \geq 10$	(65)	(70)	--	deg	Note 1
		θ_L		(65)	(70)	--		
	Vertical	θ_T		(55)	(60)	--		
		θ_B		(55)	(60)	--		
Contrast Ratio		CR	at optimized viewing angle	(250)	(400)			Note 4,5
Response time	Rise	T_r	Center	-	(5)	(10)	ms	Note 3,5
	Fall	T_f	$\theta_x = \theta_y = 0^\circ$	-	(11)	(16)	ms	
Brightness		L		(240)	(280)	--	cd/m ²	Center of display
Chromaticity	x_W	Center $\theta_x = \theta_y = 0^\circ$		(0.253)	(0.313)	(0.363)		Note 2,6,7
	y_W			(0.279)	(0.329)	(0.379)		
	x_R			(0.547)	(0.597)	(0.647)		
	y_R			(0.288)	(0.338)	(0.388)		
	x_G			(0.265)	(0.315)	(0.365)		
	y_G			(0.485)	(0.535)	(0.585)		
	x_B			(0.088)	(0.138)	(0.188)		
	y_B			(0.104)	(0.154)	(0.204)		

Note 1: Definition of viewing angle range

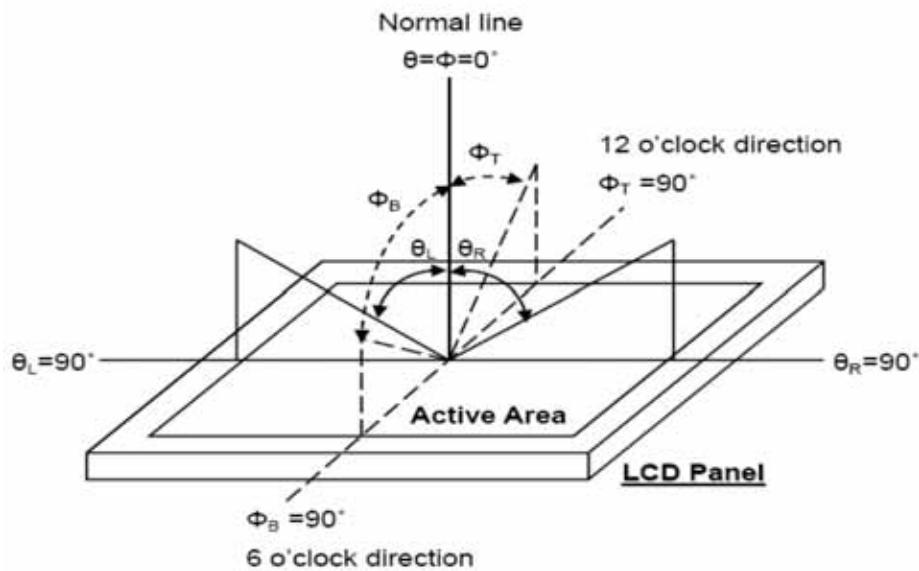

Fig. 8-1 Definition of viewing angle

Note 2: Test equipment setup:

After stabilizing and leaving the panel alone at a driven temperature for 10 minutes, the measurement should be executed. Measurement should be executed in a stable, windless, and dark room. Optical specifications are measured by Topcon BM-7 luminance meter 1.0° field of view at a distance of 50cm and normal direction.

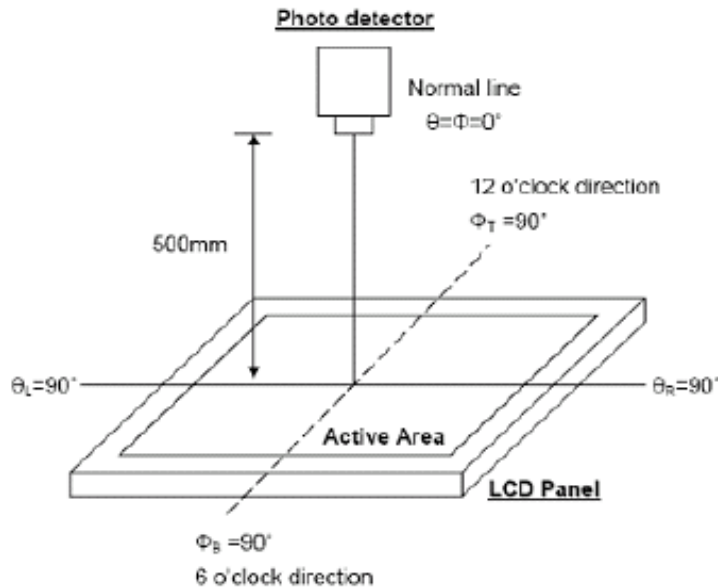

Fig. 8-2 Optical measurement system setup

Note 3: Definition of Response time:

The response time is defined as the LCD optical switching time interval between "White" state and "Black" state. Rise time, T_r , is the time between photo detector output intensity changed from 90% to 10%. And fall time, T_f , is the time between photo detector output intensity changed from 10% to 90%.

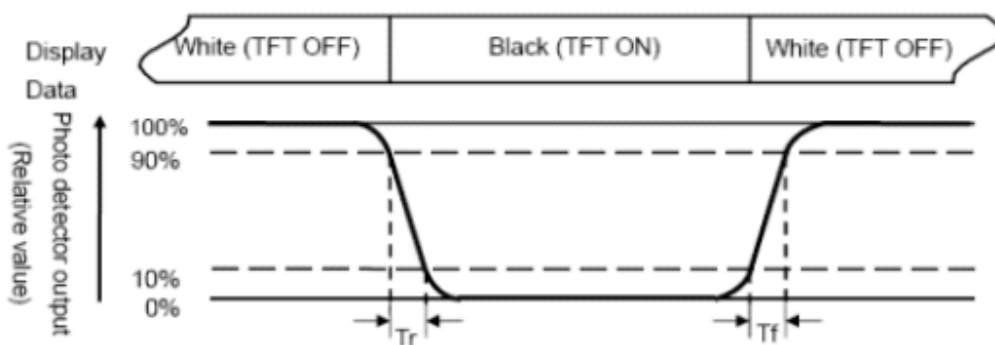

Fig. 8-3 Definition response time

Note 4: Definition of contrast ratio:

The contrast ratio is defined as the following expression.

$$\text{Contrast ratio (CR)} = \frac{\text{Luminance measured when LCD on the "White" state}}{\text{Luminance measured when LCD on the "Black" state}}$$

Note 5: White $V_i = V_{i50} \pm 1.5V$ Black $V_i = V_{i50} \pm 2.0V$

“±” means that the analog input signal swings in phase with VCOM signal.

“±” means that the analog input signal swings out of phase with VCOM signal.

The 100% transmission is defined as the transmission of LCD panel when all the input terminals of module are electrically opened.

Note 6: Definition of color chromaticity (CIE 1931)

Color coordinates measured at the center point of LCD

Note 7: Measured at the center area of the panel when all the input terminals of LCD panel are electrically opened.

$$\text{Note 8 : Uniformity (U)} = \frac{\text{Brightness (min)}}{\text{Brightness (max)}} \times 100\%$$

10. PIN CONNECTIONS

Pin No.	Symbol	Description	Remark
1	GND	Ground for gate drive	
2	VCC	Digital voltage for gate driver	
3	VGL	TFT low voltage	
4	VGH	TFT high voltage	
5	STVL	Start pulse signal input/output (Vertical)	
6	STVR	Start pulse signal input/output (Vertical)	
7	CKV	CLK (Vertical)	
8	U/D	Up or Down display control	
9	OEV	Output enable	
10	VCOM	VCOM voltage	
11	DIO1	Start pulse signal input/output (Horizontal)	
12	AVDD	Analog voltage for source driver	
13	AVSS	Analog ground for source driver	
14	GND	Digital ground for source driver	
15	VCC(DVDD)	Digital voltage for source driver	
16	EDGSL	Select raising edge or raising/falling edge	
17	CLK	Sample CLK	
18	SHL(R/L)	Right or Left display control	
19	R0	Red data	
20	R1	Red data	
21	R2	Red data	
22	R3	Red data	
23	R4	Red data	
24	R5	Red data	
25	G0	Green Data	
26	G1	Green Data	
27	G2	Green Data	
28	G3	Green Data	
29	G4	Green Data	
30	G5	Green Data	
31	V1	Reference voltage	
32	V2	Reference voltage	
33	V3	Reference voltage	
34	V4	Reference voltage	
35	V5	Reference voltage	
36	V6	Reference voltage	
37	V7	Reference voltage	
38	V8	Reference voltage	
39	V9	Reference voltage	
40	V10	Reference voltage	
41	B0	Blue Data	
42	B1	Blue Data	
43	B2	Blue Data	
44	B3	Blue Data	
45	B4	Blue Data	
46	B5	Blue Data	
47	LD(OEH)	Latch and switch data to output	

48	REV	Control data are inverted or not	
49	POL	Polarity selection	
50	DIO2	Start pulse signal input/output(Horizontal)	

10.1 Backlight Driving Part

Pin No.	Symbol	Description
1	VLED+	Red, LED_ Anode
2	VLED-	White, LED_ Cathode

Note: The backlight interface connector is a model **SM02B-BHSS-1-TB** manufactured by JST or equivalent. The matching connector part number is **BHSR-20VS-1** manufactured by JST or equivalent.

11. BLOCK DIAGRAM

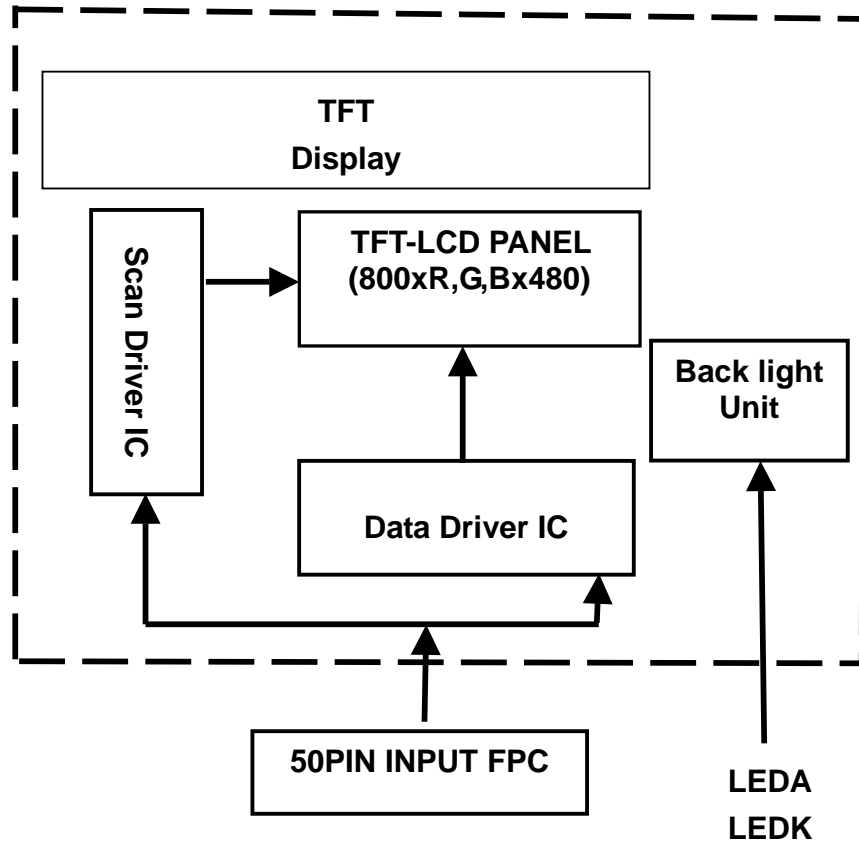

12. TOUCH PANEL CHARACTERISTICS

1. Input Method and Activation Force

Input Method	Activation Force
0.8mm dia. Delrin Polyacetal stylus	80gf Max.
8.0mm dia. Silicon "finger"	80gf Max.

2. Typical Optical Characteristics

ITEM	Parameter
Visible Light Transmission	80% typ.
Haze	5%typ.

3. Electrical Specification

ITEM	Parameter
Operating Voltage	DC 7V Max
Circuit close resistance	X 350~1400Ω
	Y 100~800Ω
Circuit open resistance	10MΩ min at 25V DC
Contact bounce	≤20ms
Linear Test	≤1.5%

4. Linearity

ITEM	Parameter
Linear Test Specification Direction	X ≤1.5%
	Y ≤1.5%

5. Specification

ITEM	Parameter
Operating Temperature	-10°C~+60°C
Storage Temperature	-30°C~+70°C

6. Durability test:

6.1 Touch panel is hit 1 millions times with a silicone rubber of R8 finger, hitting rate is by 200g at 2 times per second. The measurement must satisfy the following:

- Circuit close resistance: x350~1400Ω ; y 100~800Ω
- Circuit open resistance: 10MΩ min at 25V DC
- Contact bounce: ≤20ms
- Linearity test: ≤3%

6.2 Stylus writing

Touch panel is drawn by R0.8 Darling stylus pen, at 250g forces, repeat one inch by 100k times. The measurement must satisfy the following:

- Circuit close resistance: x 350~1400Ω ; y 100~800Ω
- Circuit open resistance: 10MΩ min at 25V DC
- Contact bounce: ≤20ms
- Linearity test: ≤3%

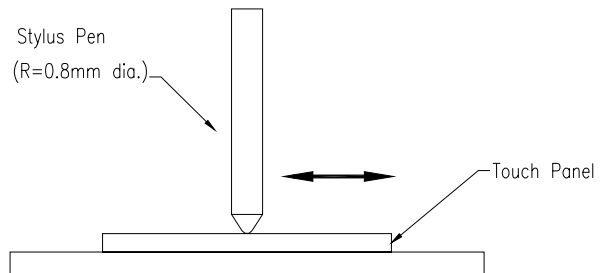
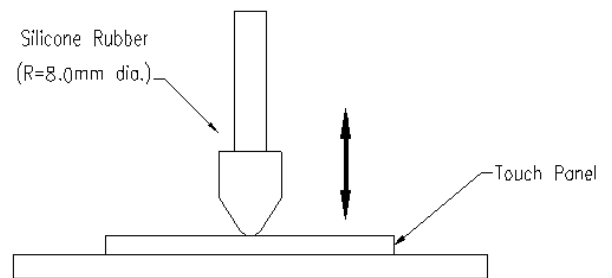

13. QUALITY ASSURANCE

Ta= Ambient Temperature

No.	Test Items	Test Condition	REMARK
1	High Temperature Storage Test	Ta =70 ,240hrs	
2	Low Temperature Storage Test	Ta =-30 ,240hrs	
3	High Temperature Operation Test	Ta =60 ,240hrs	
4	Low Temperature Operation Test	Ta =-10 ,240hrs	
5	High Temperature and High Humidity Operation Test	Ta=60 ,90%RH, 240h	
6	Electro Static Discharge Test	150pF, 330Ω , ±8KV(Contact)/ ± 15KV(Air), 5 points/panel, 5 times/point	
7	Shock Test (No operation)	Half sine wave, 180G, 2ms one shock of each six faces (I.e. run 180G 2ms for all six faces)	
8	Vibration Test (No operation)	Sine wave, 10 ~ 500 ~ 10Hz, 1.5G, 0.37oct/min 3 axis, 1hour/axis	
9	Thermal Shock Test	-10 (0.5h) ~ 60 (0.5h) / 100cycles	

14. LOT NUMBERING SYSTEM

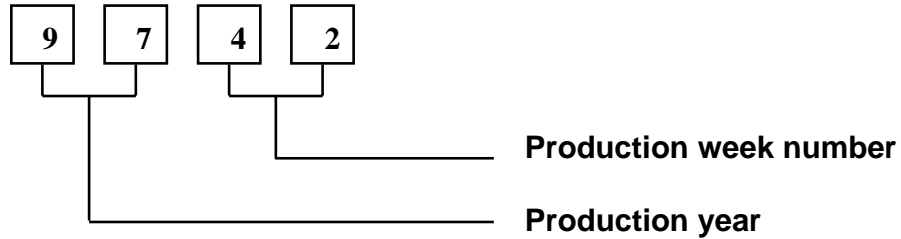

15. LCM NUMBERING SYSTEM

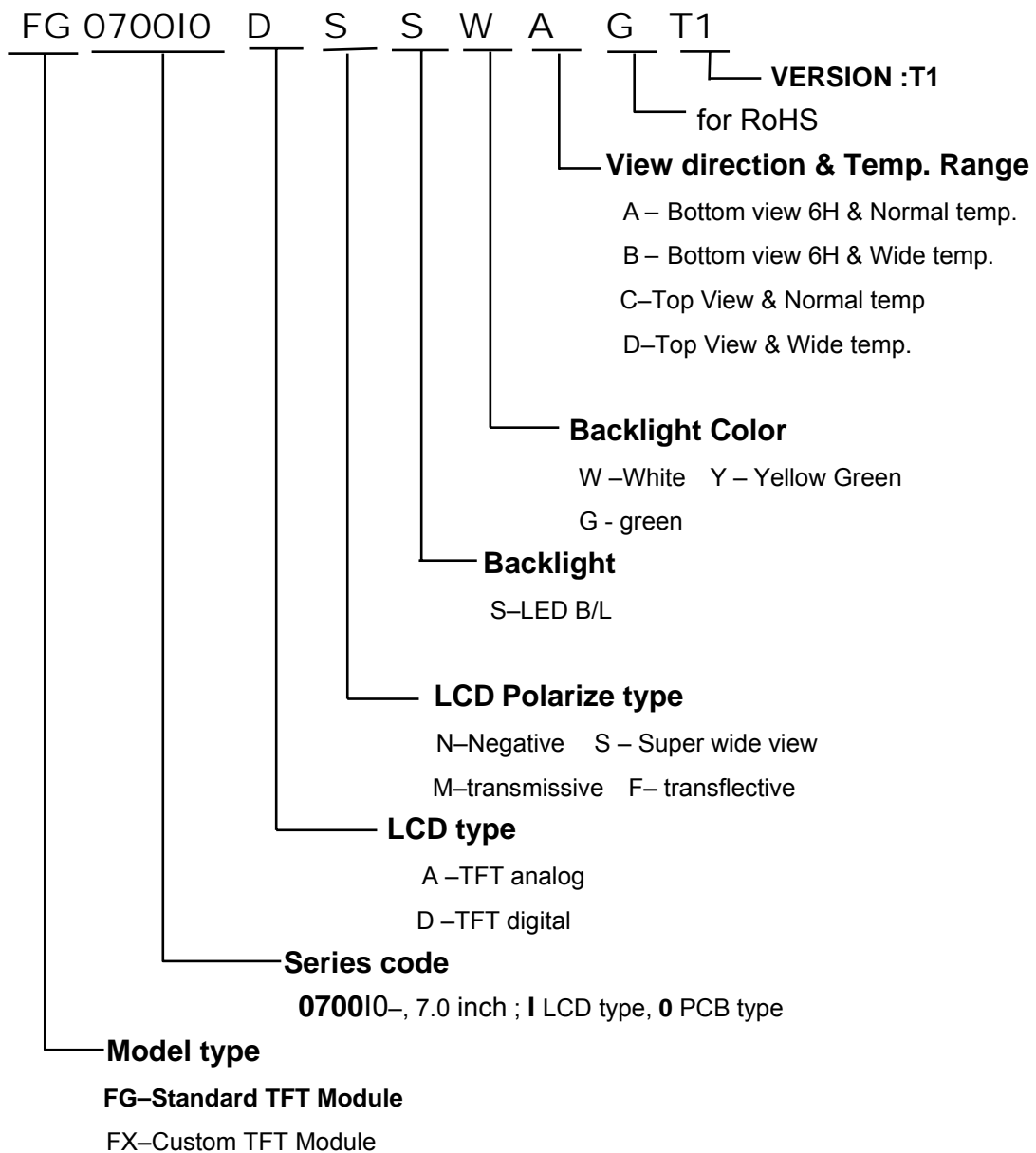

16. PRECAUTIONS IN USE LCM

1. LIQUID CRYSTAL DISPLAY (LCD)

LCD is made up of glass, organic sealant, organic fluid, and polymer based polarizers. The following precautions should be taken when handling,

- (1). Keep the temperature within range of use and storage. Excessive temperature and humidity could cause polarization degradation, polarizer peel off or bubble.
- (2). Do not contact the exposed polarizers with anything harder than an HB pencil lead. To clean dust off the display surface, wipe gently with cotton, chamois or other soft material soaked in petroleum benzine.
- (3). Wipe off saliva or water drops immediately. Contact with water over a long period of time may cause polarizer deformation or color fading, while an active LCD with water condensation on its surface will cause corrosion of ITO electrodes.
- (4). Glass can be easily chipped or cracked from rough handling, especially at corners and edges.
- (5). Do not drive LCD with DC voltage.

2. Liquid Crystal Display Modules

2.1 Mechanical Considerations

LCM are assembled and adjusted with a high degree of precision. Avoid excessive shocks and do not make any alterations or modifications. The following should be noted.

- (1). Do not tamper in any way with the tabs on the metal frame.
- (2). Do not modify the PCB by drilling extra holes, changing its outline, moving its components or modifying its pattern.
- (3). Do not touch the elastomer connector, especially insert an backlight panel (for example, EL).
- (4). When mounting a LCM make sure that the PCB is not under any stress such as bending or twisting. Elastomer contacts are very delicate and missing pixels could result from slight dislocation of any of the elements.
- (5). Avoid pressing on the metal bezel, otherwise the elastomer connector could be deformed and lose contact, resulting in missing pixels.

2.2. Static Electricity

LCM contains CMOS LSI's and the same precaution for such devices should apply, namely

- (1). The operator should be grounded whenever he/she comes into contact with the module. Never touch any of the conductive parts such as the LSI pads, the copper leads on the PCB and the interface terminals with any parts of the human body.
- (2). The modules should be kept in antistatic bags or other containers resistant to static for storage.
- (3). Only properly grounded soldering irons should be used.
- (4). If an electric screwdriver is used, it should be well grounded and shielded from commutator sparks.

- (5) The normal static prevention measures should be observed for work clothes and working benches; for the latter conductive (rubber) mat is recommended.
- (6). Since dry air is inductive to statics, a relative humidity of 50-60% is recommended.

2.3 Soldering

- (1). Solder only to the I/O terminals.
- (2). Use only soldering irons with proper grounding and no leakage.
- (3). Soldering temperature : $280^{\circ}\text{C} \pm 10^{\circ}\text{C}$
- (4). Soldering time: 3 to 4 sec.
- (5). Use eutectic solder with resin flux fill.
- (6). If flux is used, the LCD surface should be covered to avoid flux spatters. Flux residue should be removed after wards.

2.4 Operation

- (1). The viewing angle can be adjusted by varying the LCD driving voltage V_0 .
- (2). Driving voltage should be kept within specified range; excess voltage shortens display life.
- (3). Response time increases with decrease in temperature.
- (4). Display may turn black or dark blue at temperatures above its operational range; this is (however not pressing on the viewing area) may cause the segments to appear "fractured".
- (5). Mechanical disturbance during operation (such as pressing on the viewing area) may cause the segments to appear "fractured".

2.5 Storage

If any fluid leaks out of a damaged glass cell, wash off any human part that comes into contact with soap and water. Never swallow the fluid. The toxicity is extremely low but caution should be exercised at all the time.

2.6 Limited Warranty

Unless otherwise agreed between DATA IMAGE and customer, DATA IMAGE will replace or repair any of its LCD and LCM which is found to be defective electrically and visually when inspected in accordance with DATA IMAGE acceptance standards, for a period on one year from date of shipment. Confirmation of such date shall be based on freight documents. The warranty liability of DATA IMAGE is limited to repair and/or replacement on the terms set forth above. DATA IMAGE will not responsible for any subsequent or consequential events.

Confidential Document
17. OUTLINE DRAWING

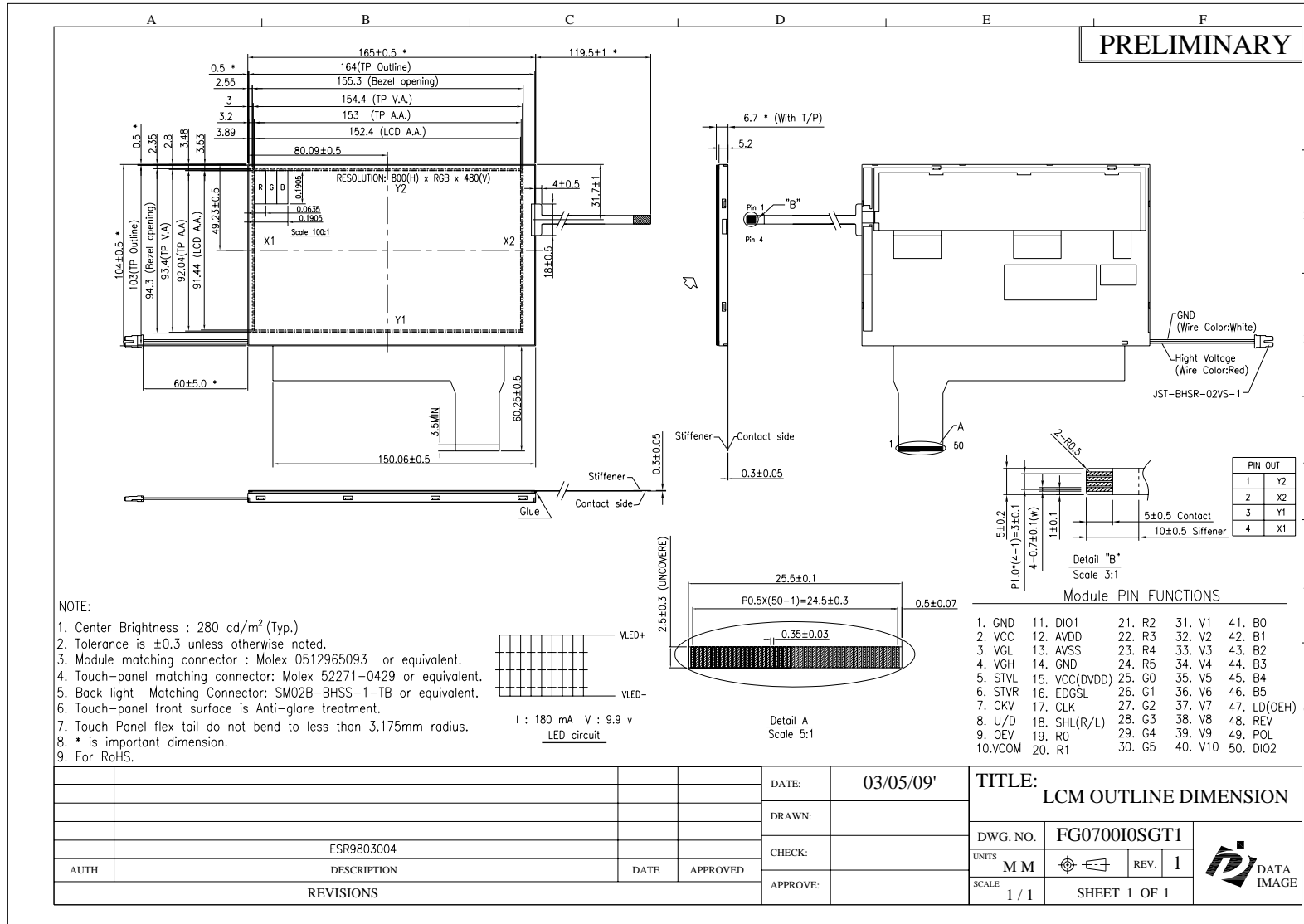

18. PACKAGE INFORMATION

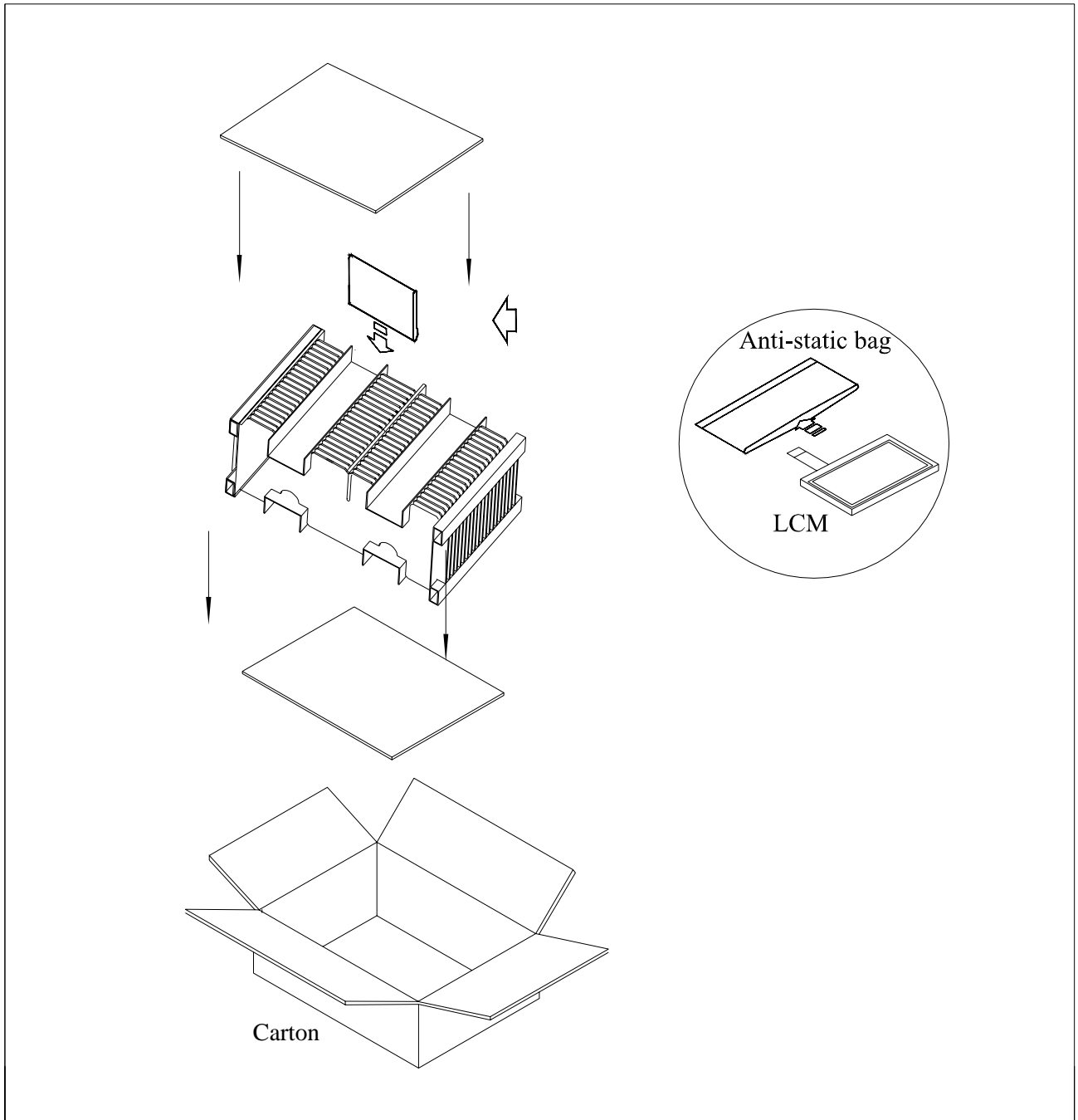

Item	Size(L*W*H)	Quantity	Note
Master Carton	482*282*279	1	
Quantity Per Master Carton		30	
N . W	4.8 (kg)	G . W	6.3 (kg)