

# DATA IMAGE CORPORATION

## TFT Module Specification

ITEM NO.: FG050722DSSWDGL2

### Table of Contents

1. COVER & CONTENTS .....	1
2. RECORD OF REVISION .....	2
3. APPLICATION.....	3
4. GENERAL SPECIFICATIONS .....	3
5. ABSOLUTE MAXIMUM RATINGS .....	3
6. ELECTRICAL CHARACTERISTICS .....	3
7. BLOCK DIAGRAM .....	4
8. PIN CONNECTIONS .....	5
9. INTERFACE SPECIFICATIONS .....	7
10. OPTICAL CHARACTERISTIC .....	12
11. QUALITY ASSURANCE .....	15
12. LCM PRODUCT LABEL DEFINE.....	19
13. PRECAUTIONS IN USE LCM .....	21
14. OUTLINE DRAWING .....	22
15. PACKAGE INFORMATION .....	23

Customer Companies	R&D Dept.	Q.C. Dept.	Eng. Dept.	Prod. Dept.
	ALEX	JOE	GARY	KEN
Approved by	Version:	Issued Date:	Sheet Code:	Total Pages:
	B	27/NOV/14'		23

**2. RECORD OF REVISION**

Rev	Date	Item	Page	Comment
1	25/OCT/12'			Initial preliminary
A	1/JUL/13'	6 10 11.1.5 11.2 14	3 12 15 16 22	1. Add ILED data. 2. Add CR data. 3. Add Remark. 4. Add Inspection condition. 5. Modify Outline Drawing from Rev.1 to A. 6. Release Rev: A for production.
B	27/NOV/14'	3	3	Modify LED Dice life time.

### 3. APPLICATION

Digital equipments which need color display, such as P.O.S, medical equipments and industrial equipments.

### 4. GENERAL SPECIFICATIONS

Parameter	Specifications	Unit
Display resolution	(640X R.G.B) (W) x480(H)	dot
Active area	115.2(W) x 86.4(H)	mm
Screen size	5.7(Diagonal)	inch
Dot pitch	0.06(W) x 0.18(H)	mm
Color configuration	R.G.B. Stripe	
Overall dimension	127 (W) x 98.43(H) x 8.9Max.(T)	mm
Weight	110	g
Surface treatment	Clear	
View Angle direction(Gray inversion)	12 o'clock	
Our components and processes are compliant to RoHS standard		

### 5. ABSOLUTE MAXIMUM RATINGS

Parameter	Symbol	MIN.	MAX.	Unit	Remark
Power supply voltage	V <sub>CC</sub>	-0.3	5.0	V	
Logic input voltage	V <sub>I</sub>	-0.3	V <sub>CC</sub> +0.3	V	
Operating temperature	Top	-20	+70	°C	Ambient temperature
Storage temperature	T <sub>st</sub>	-30	+80	°C	Ambient temperature

### 6. ELECTRICAL CHARACTERISTICS

GND=0V,DCLK=25MHz,Ta=25°C

Parameter	Symbol	MIN.	Typ.	MAX.	Unit	Remark
Power Supply voltage for LCD	V <sub>CC</sub>	+3.0	+3.3	+3.6	V	
Power Supply Current for LCD	I <sub>CC</sub>		123	150	mA	V <sub>CC</sub> =3.3V
Power Supply voltage for LED	V <sub>LED</sub>	4.5	5	5.5	V	
Power Supply Current for LED	I <sub>LED</sub>	--	333	400	mA	V <sub>LED</sub> =5.0V
Ripple voltage	V <sub>RF</sub>	-	-	100	mV <sub>P-P</sub>	
"H" level logical input voltage	V <sub>IH</sub>	0.7V <sub>CC</sub>	--	V <sub>CC</sub>	V	
"L" level logical input voltage	V <sub>IL</sub>	0	--	0.3V <sub>CC</sub>	V	
ADJ frequency		19K	20K	21K	Hz	
ADJ input voltage	V <sub>IH</sub>	3.0	-	3.3	V	
	V <sub>IL</sub>	0	-	0.3	V	
LED Dice life time		--	50,000	--	Hr	Note 1

Note 1: The "LED dice life time" is defined as the brightness decrease to 50% original brightness that the ambient temperature is 22°C and LED dice current=20mA.

## 7. BLOCK DIAGRAM

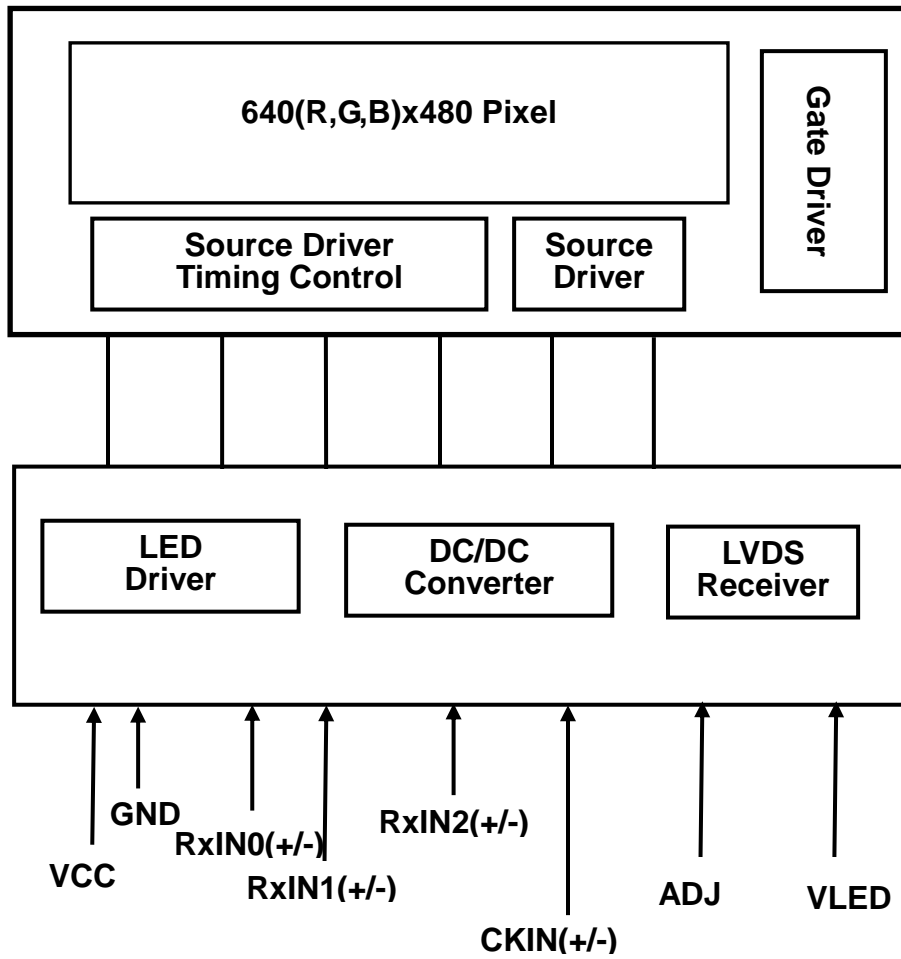

## 8. PIN CONNECTIONS

Pin No	Symbol	Function	Remark
1	VCC	power supply for Digital Circuit	
2	VCC	power supply for Digital Circuit	
3	GND	Ground	
4	GND	Ground	
5	RxIN0-	Differential Data Input ,CH0(Negative)	
6	RxIN0+	Differential Data Input ,CH0(Positive)	
7	GND	Ground	
8	RxIN1-	Differential Data Input ,CH1(Negative)	
9	RxIN1+	Differential Data Input ,CH1(Positive)	
10	GND	Ground	
11	RxIN2-	Differential Data Input ,CH2(Negative)	
12	RxIN2+	Differential Data Input ,CH2(Positive)	
13	GND	Ground	
14	CKIN-	Differential Clock Input (Negative)	
15	CKIN+	Differential Clock Input (Positive)	
16	GND	Ground	
17	VLED	Power Supply for LED Driver Circuit	
18	VLED	Power Supply for LED Driver Circuit	
19	GND	Ground	
20	ADJ	Brightness control for LED B/L	

Remarks :

- 1) ADJ is brightness control Pin. The larger of the pulse duty is, the higher of the brightness.
- 2) ADJ signal is 0~3.3V. Operation frequency is 20KHz
- 3) GND PIN must be grounding, can not be floating.

### 8.1 Power Signal Sequence

Remarks:

\*1) Power Signal sequence:

$t1 \leq 10\text{ms}$  :  $1\text{sec} \leq t5$

$50\text{ms} \leq t2$  :  $200\text{ms} \leq t6$

$0 < t3 \leq 50\text{ms}$  :  $200\text{ms} \leq t7$

$0 < t4 \leq 10\text{ms}$

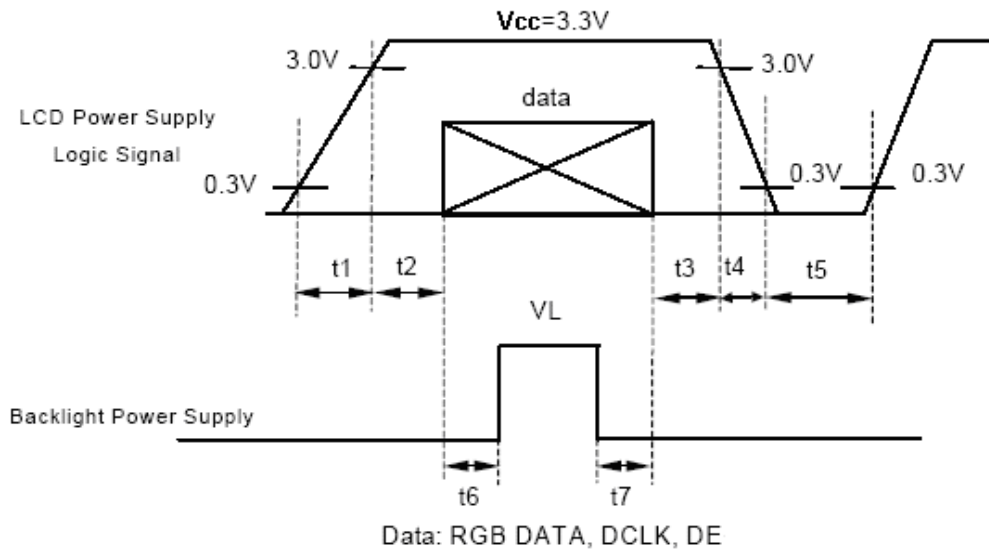

\*2) VCC-dip condition:

(1)  $2.7\text{V} \leq V_{CC} < 3.0\text{V}$ ,  $t_d \leq 10\text{ms}$

(2)  $V_{CC} > 3.0\text{V}$ , VCC-dip condition should be the same with VCC-turn-on condition.

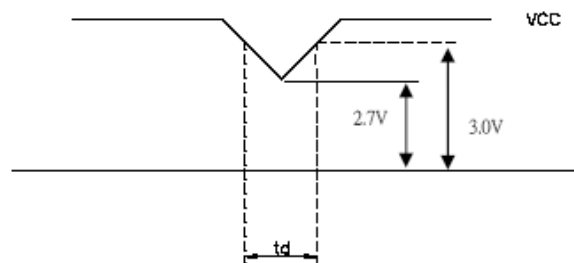

## 9. INTERFACE SPECIFICATIONS

### 9.1 DE mode Input signal characteristics

Signal	Parameter	Symbol	MIN.	TYP.	MAX.	Unit	Remarks
DCLK	Period	$t_{CLK}$	33	40	43	ns	
	Frequency	$f_{CLK}$	23	25	30	MHz	
	Low Level Width	$t_{WCL}$	6	-	-	ns	
	High Level Width	$t_{WCH}$	6	-	-	ns	
	Rise, Fall Time (1)	$t_{CLKr}, t_{CLKf}$	-	-	3	ns	
	Duty	-	0.45	0.50	0.55	-	
DE (Data Enable)	Setup Time	$t_{DES}$	5	-	-	ns	
	Hold Time	$t_{DEH}$	10	-	-	ns	
	Rise, Fall Time	$t_{DEr}, t_{DEf}$	-	-	16	ns	
	Horizontal Period	$t_{HP}$	750	800	900	$t_{CLK}$	
	Horizontal Valid	$t_{HV}$	640	640	640	$t_{CLK}$	
	Horizontal Blank	$t_{HBK}$	110	160	260	$t_{CLK}$	
	Vertical Period	$t_{VP}$	515	525	560	$t_{HP}$	
	Vertical Valid	$t_{V}$	480	480	480	$t_{HP}$	
	Vertical Blank	$t_{VBK}$	35	45	80	$t_{HP}$	
	Vertical Frequency	$f_v$	55	60	65	Hz	
Data R,G,B	Setup Time	$t_{DS}$	5	-	-	ns	
	Hold Time	$t_{DH}$	10	-	-	ns	
	Rise, Fall Time	$t_{Dr}, t_{Df}$	-	-	3	ns	

Note: (1)  $t_{CLKL} / t_{CLK}$ .

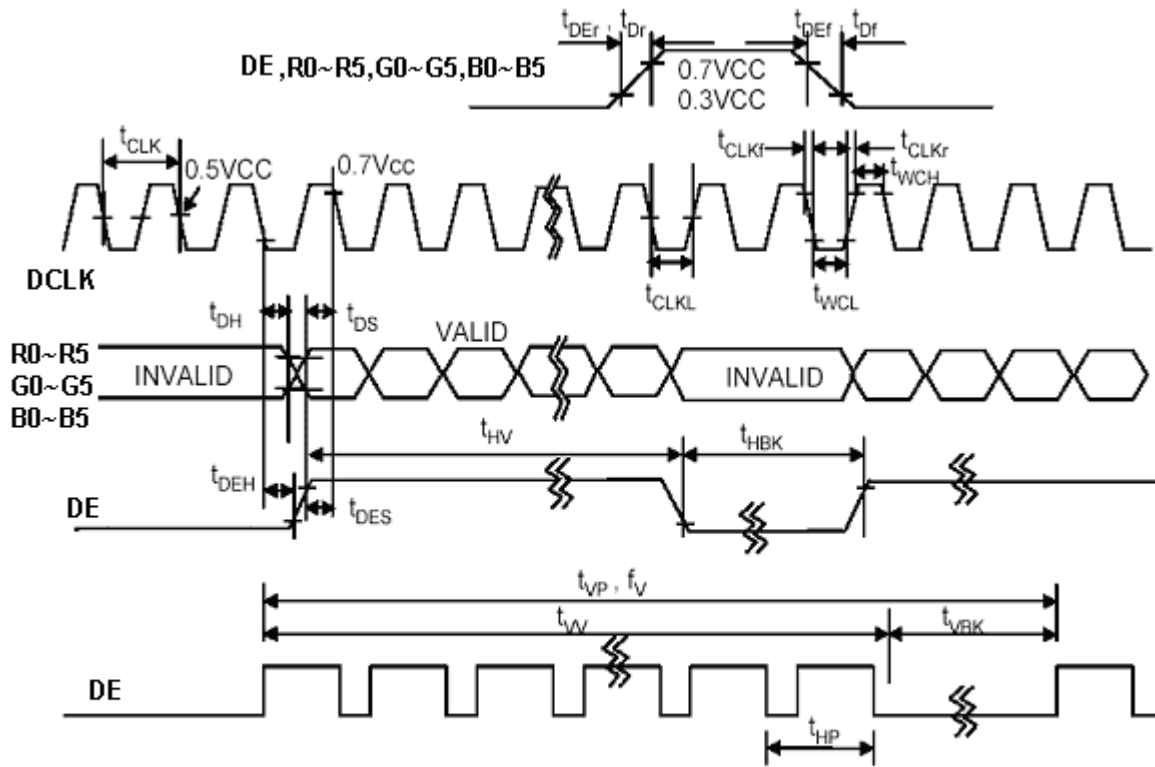
**9.1.1 DE mode timing waveform**



### 9.2 SYNC mode Input signal characteristics

Parameter	Symbol	MIN.	TYP.	MAX.	Unit	Remarks
Clock Period	$t_{CLK}$	33	40	43	ns	
Clock Frequency	$f_{CLK}$	23	25	30	MHz	
Clock Low Level Width	$t_{WCL}$	6	-	-	ns	
Clock High Level Width	$t_{WCH}$	6	-	-	ns	
Clock Rise, Fall Time	$t_{CLKr}, t_{CLKf}$	-	-	3	ns	
HSYNC Period	$t_{HP}$	750	800	900	$t_{CLK}$	
HSYNC Pulse Width	$t_{HW}$	5	30	-	$t_{CLK}$	
HSYNC Front Porch	$t_{HFP}$	1	16	116	$t_{CLK}$	
HSYNC Back Porch	$t_{HBP}$	1	114	139	$t_{CLK}$	
HSYNC Width + Back Porch	$t_{HW} + t_{HBP}$	144	144	144	$t_{CLK}$	
Horizontal Blank	$t_{HBK}$	1	160	260	$t_{CLK}$	
Horizontal Valid	$t_{HV}$	640	640	640	$t_{CLK}$	
VSYNC Period	$t_{VP}$	515	525	560	$t_{HP}$	
VSYNC Pulse Width	$t_{VW}$	1	3	5	$t_{HP}$	
VSYNC Front Porch	$t_{VFP}$	1	10	45	$t_{HP}$	
VSYNC Back Porch	$t_{VBP}$	30	32	34	$t_{HP}$	
VSYNC Width + Back Porch	$t_{VW} + t_{VBP}$	35	35	35	$t_{CLK}$	
Vertical Blank	$t_{VBK}$	35	45	80	$t_{HP}$	
Valid data Width	$t_W$	480	480	480	$t_{HP}$	
Data Setup Time	$t_{DS}$	5	-	-	ns	
Data Hold Time	$t_{DH}$	10	-	-	ns	

Note: (1)  $t_{HBK} = t_{HFP} + t_{HW} + t_{HBP}$

## 9.2.1 SYNC mode timing waveform

### 9.2.1.1 Input vertical timing

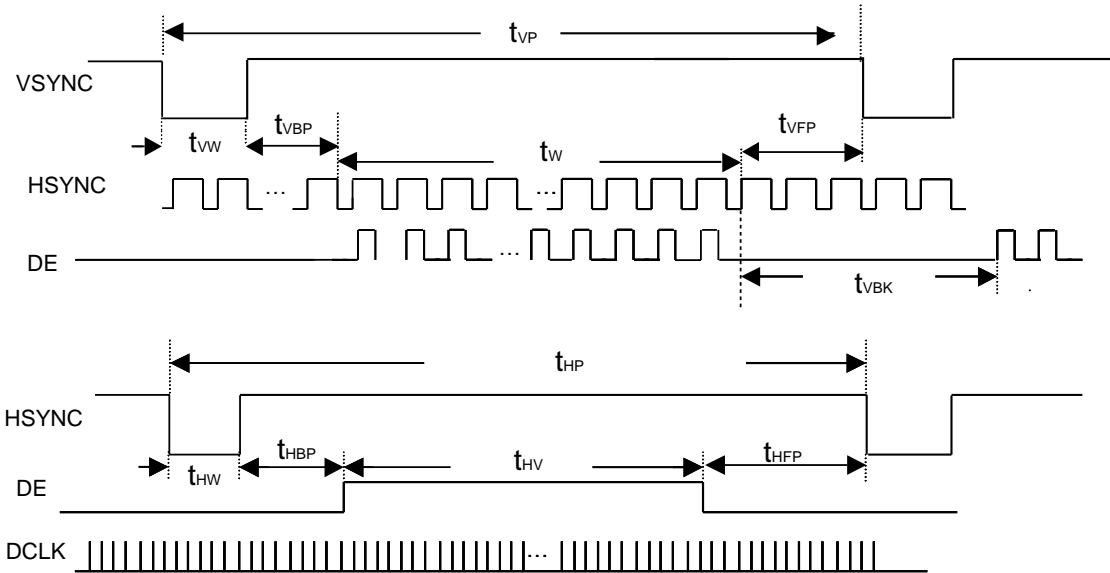

### 9.2.1.2 Input horizontal timing

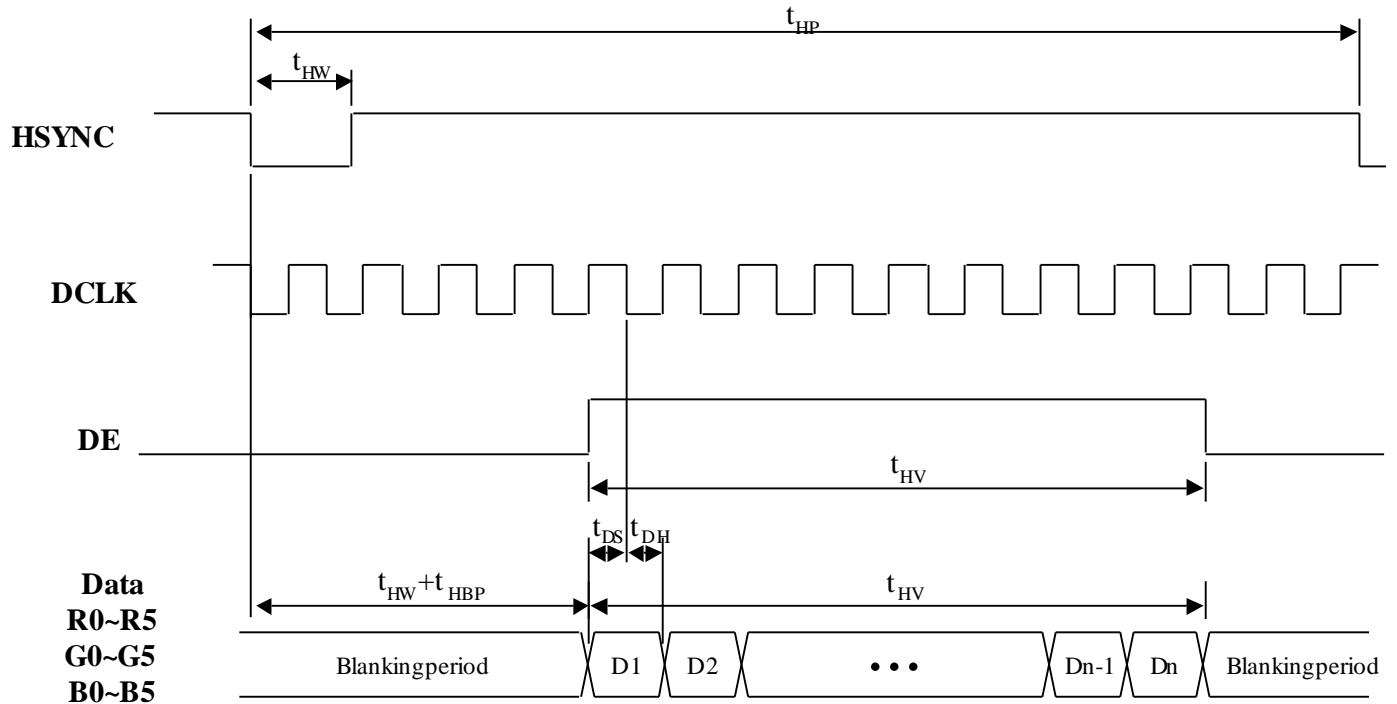

**9.3 Color Data Assignment**

COLOR	INPUT	R DATA						G DATA						B DATA					
		DATA	R5	R4	R3	R2	R1	R0	G5	G4	G3	G2	G1	G0	B5	B4	B3	B2	B1
		MSB					LSB	MSB					LSB	MSB					LSB
BASIC COLOR	BLACK	0	0	0	0	0	0	0	0	0	0	0	0	0	0	0	0	0	0
	RED(63)	1	1	1	1	1	1	0	0	0	0	0	0	0	0	0	0	0	0
	GREEN(63)	0	0	0	0	0	0	1	1	1	1	1	1	0	0	0	0	0	0
	BLUE(63)	0	0	0	0	0	0	0	0	0	0	0	0	1	1	1	1	1	1
	CYAN	0	0	0	0	0	0	1	1	1	1	1	1	1	1	1	1	1	1
	MAGENTA	1	1	1	1	1	1	0	0	0	0	0	0	1	1	1	1	1	1
	YELLOW	1	1	1	1	1	1	1	1	1	1	1	1	0	0	0	0	0	0
	WHITE	1	1	1	1	1	1	1	1	1	1	1	1	1	1	1	1	1	1
RED	RED(0)	0	0	0	0	0	0	0	0	0	0	0	0	0	0	0	0	0	0
	RED(1)	0	0	0	0	0	1	0	0	0	0	0	0	0	0	0	0	0	0
	RED(2)	0	0	0	0	1	0	0	0	0	0	0	0	0	0	0	0	0	0
	:	:	:	:	:	:	:	:	:	:	:	:	:	:	:	:	:	:	:
	:	:	:	:	:	:	:	:	:	:	:	:	:	:	:	:	:	:	:
	RED(62)	1	1	1	1	1	0	0	0	0	0	0	0	0	0	0	0	0	0
	RED(63)	1	1	1	1	1	1	0	0	0	0	0	0	0	0	0	0	0	0
GREEN	GREEN(0)	0	0	0	0	0	0	0	0	0	0	0	0	0	0	0	0	0	0
	GREEN(1)	0	0	0	0	0	0	0	0	0	0	0	1	0	0	0	0	0	0
	GREEN(2)	0	0	0	0	0	0	0	0	0	0	1	0	0	0	0	0	0	0
	:	:	:	:	:	:	:	:	:	:	:	:	:	:	:	:	:	:	:
	:	:	:	:	:	:	:	:	:	:	:	:	:	:	:	:	:	:	:
	GREEN(62)	0	0	0	0	0	0	1	1	1	1	1	0	0	0	0	0	0	0
	GREEN(63)	0	0	0	0	0	0	1	1	1	1	1	1	0	0	0	0	0	0
BLUE	BLUE(0)	0	0	0	0	0	0	0	0	0	0	0	0	0	0	0	0	0	0
	BLUE(1)	0	0	0	0	0	0	0	0	0	0	0	0	0	0	0	0	0	1
	BLUE(2)	0	0	0	0	0	0	0	0	0	0	0	0	0	0	0	0	1	0
	:	:	:	:	:	:	:	:	:	:	:	:	:	:	:	:	:	:	:
	:	:	:	:	:	:	:	:	:	:	:	:	:	:	:	:	:	:	:
	BLUE(62)	0	0	0	0	0	0	0	0	0	0	0	0	1	1	1	1	1	0
	BLUE(63)	0	0	0	0	0	0	0	0	0	0	0	0	1	1	1	1	1	1

Remarks:(1) Definition of Gray Scale  
 color(n):n is series of Gray Scale  
 The more n value is, the bright Gray Scale.  
 (2)Data:1-High,0-Low

**Correspondence between Data and Display Position**

	S0001	S0002	S0003	S0004	S0005	S0006	S0007	S0008	-----	S1919	S1920
C001	R001	G001	B001	R002	G002	B002	R003	G003		G640	B640
C480	R001	G001	B001	R002	G002	B002	R003	G003		G640	B640

## 10. OPTICAL CHARACTERISTIC Specification:

Parameter	Symbol	Condition	MIN.	TYP.	MAX.	Unit	Remarks	
Viewing Angle	Horizontal	$\theta_{x+}$	60	70	--	deg	Note 1,4	
		$\theta_{x-}$	60	70	--			
	Vertical	$\theta_{y+}$	CR $\geq$ 10	50	60			--
		$\theta_{y-}$		30	40			--
Contrast Ratio	CR	at optimized viewing angle	200	300			Note 1,3	
Response time	Rise	Tr	-	15		ms	Note 1,6	
	Fall	Tf	$\theta_x=\theta_y=0^\circ$	35		ms		
Uniformity	B-uni	$\theta_x=\theta_y=0^\circ$	70	80	--	%	Note1,5	
Brightness	L	$\theta_x=\theta_y=0^\circ$ ADJ=3.3V	720	900	--	cd/m <sup>2</sup>	Note 1,2	
Chromaticity	$x_W$	Center $\theta_x=\theta_y=0^\circ$	0.259	0.309	0.359		Note 1,7	
	$y_W$		0.270	0.320	0.370			
	$x_R$		0.565	0.615	0.665			
	$y_R$		0.310	0.360	0.410			
	$x_G$		0.295	0.345	0.395			
	$y_G$		0.490	0.540	0.590			
	$x_B$		0.098	0.148	0.198			
	$y_B$		0.056	0.106	0.156			
Image sticking	tis	2 hours			2	Sec	Note 8	

The following optical specifications shall be measured in a darkroom or equivalent state (ambient luminance  $\leq 1$  lux, and at room temperature). The operation temperature is  $25^\circ\text{C} \pm 2^\circ\text{C}$ . The measurement method is shown in Note1.

Note1: The method of optical measurement:

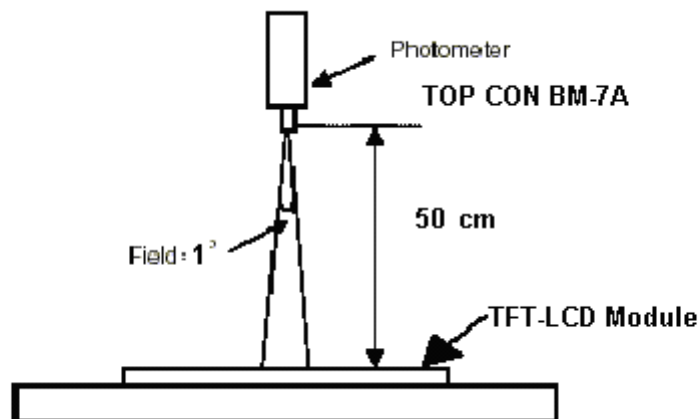

Note2: Measured at the center area of the panel and at the viewing angle of the  $\theta_x = \theta_y = 0^\circ$

Note3: Definition of Contrast Ratio (CR):

$$CR = \frac{\text{Luminance with all pixels in white state}}{\text{Luminance with all pixels in Black state}}$$

Note4: Definition of Viewing Angle

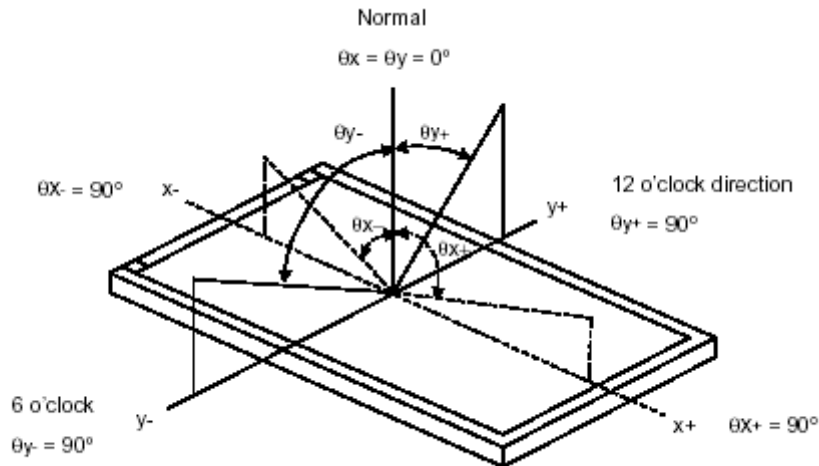

Note 5: Definition of Brightness Uniformity (B-uni):

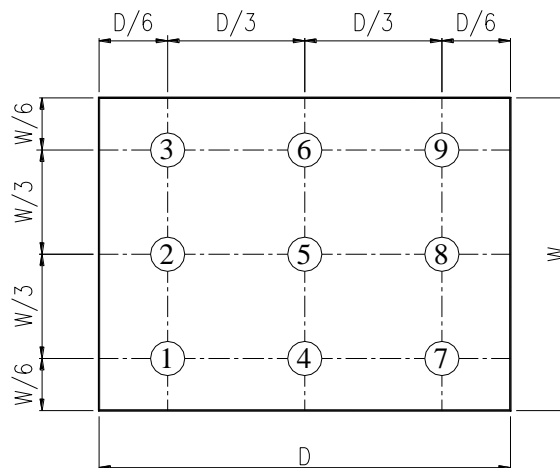

$$B\text{-uni} = \frac{\text{Minimum luminance of 9 points}}{\text{Maximum luminance of 9 points}} \quad (\text{Note 5}).$$

**Note6: Definition of Response Time:**

The Response Time is set initially by defining the "Rising Time ( $T_r$ )" and the "Falling Time ( $T_f$ )" respectively.  $T_r$  and  $T_f$  are defined as following figure.

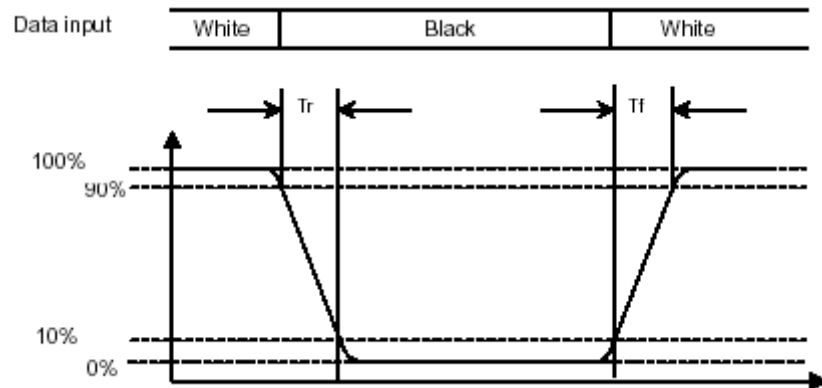
**Note 7: Definition of Chromaticity:**

The color coordinates  $(x_w, y_w)$ ,  $(x_r, y_r)$ ,  $(x_g, y_g)$ , and  $(x_b, y_b)$  are obtained with all pixels in the viewing field at white, red, green, and blue states, respectively.

**Note 8: Definition of Image sticking (tis):**

Continuously display the test pattern shown in the figure below for 2 hours. Then display a completely white screen. The previous image shall not persist more than 2 sec at 25 °C

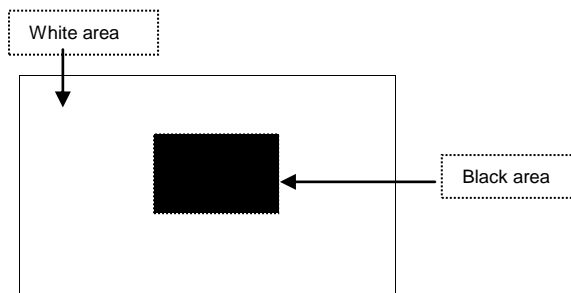
**Image sticking pattern**

## 11. QUALITY ASSURANCE

### 11.1 Test Condition

#### 11.1.1 Temperature and Humidity(Ambient Temperature)

Temperature :  $25 \pm 5^{\circ}\text{C}$

Humidity :  $65 \pm 5\%$

#### 11.1.2 Operation

Unless specified otherwise, test will be conducted under function state.

#### 11.1.3 Container

Unless specified otherwise, vibration test will be conducted to the product itself without putting it in a container.

#### 11.1.4 Test Frequency

In case of related to deterioration such as shock test. It will be conducted only once.

#### 11.1.5 Test Method

No.	Reliability Test Item & Level	Test Level	Remark
1	High Temperature Storage Test	T=80°C,240hrs	IEC68-2-2
2	Low Temperature Storage Test	T=-30°C,240hrs	IEC68-2-1
3	High Temperature Operation Test	T=70°C,240hrs	IEC68-2-2
4	Low Temperature Operation Test	T=-20°C,240hrs	IEC68-2-1
5	High Temperature and High Humidity Operation Test	T=60°C,90% RH,240hrs	IEC68-2-3
6	Thermal Cycling Test (No operation)	-30°C → +25°C → +80°C,200 Cycles 30 min 5min 30 min	IEC68-2-14
7	Vibration Test (No operation)	Frequency:0 ~ 55 Hz Amplitude:1.5 mm Sweep Time:11min Test Period:6 Cycles for each Direction of X,Y,Z	IEC68-2-6
8	Electrostatic Discharge Test (No operation)	150pF,330Ω Air:± 12KV;Contact: ±6KV 10 times/point;4 points/panel face	IEC-61000-4-2

## 11.2 Inspection condition

### 11.2.1 Inspection conditions

11.2.1.1 Inspection Distance :  $35 \pm 5$  cm

11.2.1.2 View Angle : Inspection under test condition :  $\pm 5^\circ$

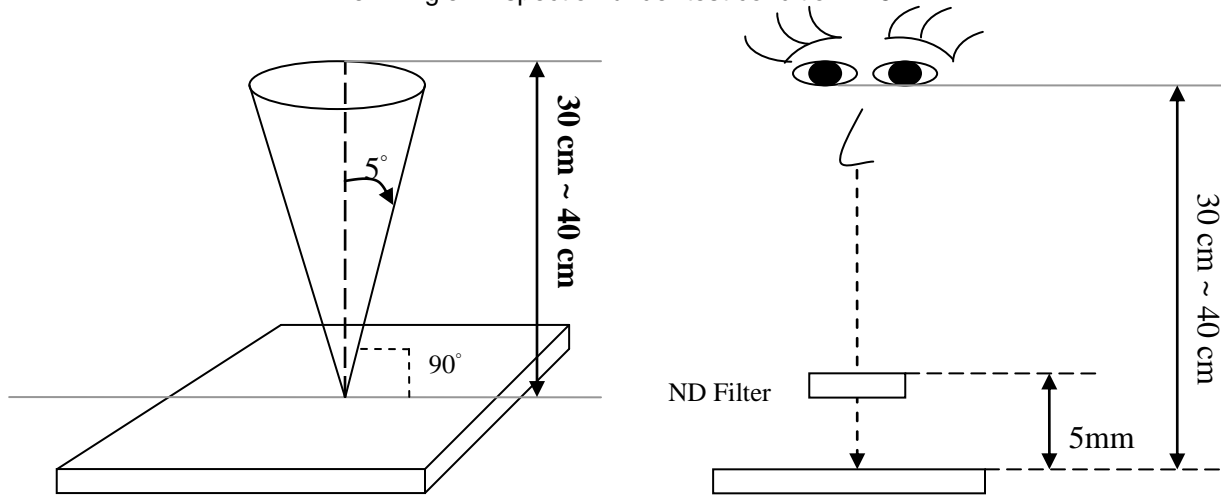

### 11.2.2 Environment conditions :

Ambient Temperature :		<b>25±5°C</b>
Ambient Humidity :		<b>65±5%</b>
Ambient Illumination	Cosmetic Inspection	<b>300 ~ 600 lux</b>
	Functional Inspection	<b>300 ~ 500 lux</b>

### 11.2.3 Definition of applicable Zones





11.2.4 Inspection Parameters

No.	Parameter	Criteria										
1	Operating	Display function: No Display malfunction (Major)										
		Contrast ratio (Black, White): Does not meet specified range in the spec. (Major) (Note:3)										
		Line Defect: No obvious Vertical and Horizontal line defect in bright, dark and colored. (Major) (Note:1)										
		Point Defect : Active area $\leq 5$ dots (Minor) (Note:1)										
		<table border="1"> <thead> <tr> <th rowspan="2">Item</th> <th>Acceptable number</th> <th rowspan="2">Total</th> </tr> <tr> <th>Active Area</th> </tr> </thead> <tbody> <tr> <td>Bright</td> <td>2</td> <td rowspan="2">5</td> </tr> <tr> <td>Dark</td> <td>4</td> </tr> </tbody> </table>	Item	Acceptable number	Total	Active Area	Bright	2	5	Dark	4	
		Item		Acceptable number		Total						
Active Area												
Bright	2	5										
Dark	4											
Non-uniformity: Visible through 5%ND filter. (Minor)												
Foreign material in Black or White spots shape ( $W > 1/4L$ )												
<table border="1"> <thead> <tr> <th>Zone Dimension</th> <th>Acceptable number</th> <th>Class Of Defects</th> <th>AQL Level</th> </tr> </thead> <tbody> <tr> <td><math>D &gt; 0.5</math></td> <td>0</td> <td rowspan="3">Minor</td> <td rowspan="3">1.5</td> </tr> <tr> <td><math>0.3 &lt; D \leq 0.5</math></td> <td>5</td> </tr> <tr> <td><math>D \leq 0.3</math></td> <td>*</td> </tr> </tbody> </table> <p><math>D = (\text{Long} + \text{Short}) / 2</math> * : Disregard</p>	Zone Dimension	Acceptable number	Class Of Defects	AQL Level	$D > 0.5$	0	Minor	1.5	$0.3 < D \leq 0.5$	5	$D \leq 0.3$	*
Zone Dimension	Acceptable number	Class Of Defects	AQL Level									
$D > 0.5$	0	Minor	1.5									
$0.3 < D \leq 0.5$	5											
$D \leq 0.3$	*											
Foreign Material in Line or spiral shape ( $W \leq 1/4L$ ) (Note: 4)												
<table border="1"> <thead> <tr> <th>Zone L (mm) \ W(mm)</th> <th>Acceptable number</th> <th>Class Of Defects</th> <th>AQL Level</th> </tr> </thead> <tbody> <tr> <td><math>L &gt; 5</math>    <math>W &gt; 0.1</math></td> <td>0</td> <td rowspan="3">Minor</td> <td rowspan="3">1.5</td> </tr> <tr> <td><math>0.5 &lt; L \leq 5</math>    <math>0.03 &lt; W \leq 0.1</math></td> <td>5</td> </tr> <tr> <td><math>L \leq 0.5</math>    <math>W \leq 0.03</math></td> <td>*</td> </tr> </tbody> </table> <p>L : Length    W : Width    * : Disregard</p>	Zone L (mm) \ W(mm)	Acceptable number	Class Of Defects	AQL Level	$L > 5$ $W > 0.1$	0	Minor	1.5	$0.5 < L \leq 5$ $0.03 < W \leq 0.1$	5	$L \leq 0.5$ $W \leq 0.03$	*
Zone L (mm) \ W(mm)	Acceptable number	Class Of Defects	AQL Level									
$L > 5$ $W > 0.1$	0	Minor	1.5									
$0.5 < L \leq 5$ $0.03 < W \leq 0.1$	5											
$L \leq 0.5$ $W \leq 0.03$	*											
2	External Inspection (non-operating)	Dimension: Outline (Major)										
		Bezel appearance: uneven (Minor)										
		Scratch on the polarize: (Note:2)										
		<table border="1"> <thead> <tr> <th>Zone L (mm) \ W(mm)</th> <th>Acceptable number</th> <th>Class Of Defects</th> <th>AQL Level</th> </tr> </thead> <tbody> <tr> <td>--    <math>W &gt; 0.1</math></td> <td>0</td> <td rowspan="2">Minor</td> <td rowspan="2">1.5</td> </tr> <tr> <td><math>L \leq 3</math>    <math>W \leq 0.1</math></td> <td>3</td> </tr> </tbody> </table> <p>L : Length    W : Width    * : Disregard</p>	Zone L (mm) \ W(mm)	Acceptable number	Class Of Defects	AQL Level	-- $W > 0.1$	0	Minor	1.5	$L \leq 3$ $W \leq 0.1$	3
		Zone L (mm) \ W(mm)	Acceptable number	Class Of Defects	AQL Level							
-- $W > 0.1$	0	Minor	1.5									
$L \leq 3$ $W \leq 0.1$	3											
Dent or bubble on the polarize (Note:2)												
<table border="1"> <thead> <tr> <th>Zone Dimension</th> <th>Acceptable number</th> <th>Class Of Defects</th> <th>AQL Level</th> </tr> </thead> <tbody> <tr> <td><math>D \leq 0.3</math></td> <td>*</td> <td rowspan="2">Minor</td> <td rowspan="2">1.5</td> </tr> <tr> <td><math>D \leq 0.5</math></td> <td>3</td> </tr> </tbody> </table> <p><math>D = (\text{Long} + \text{Short}) / 2</math> * : Disregard</p>	Zone Dimension	Acceptable number	Class Of Defects	AQL Level	$D \leq 0.3$	*	Minor	1.5	$D \leq 0.5$	3		
Zone Dimension	Acceptable number	Class Of Defects	AQL Level									
$D \leq 0.3$	*	Minor	1.5									
$D \leq 0.5$	3											

Class of defects			Definition
	<b>Major</b>	AQL 0.65%	It is a defect that is likely to result in failure or to reduce materially the usability of the product for the intended function.
<b>Minor</b>	AQL 1.5%	It is a defect that will not result in functioning problem with deviation classified.	

- Note:1.(a)Bright point defect is defined as point defect of R,G,B with area  $>1/2$  dot respectively  
 (b)Dark point defect is defined as visible in full white pattern.  
 (c)Definition of distribution of point defect is as follows:  
 -minum separation between dark point defects should be larger than 5mm.  
 -minum separation between bright point defects should be larger than 5mm.  
 (d)Definition of joined bright point defect and joined dark point defect are as follows:  
 -Three or more joined bright point defects must be nil.  
 -Three joined dark point defects must be nil.  
 -Coupling of one dark and one bright point in junction is counted as one dark and bright spot with 1 pair maximum.  
 -Two Joined dark point is counted as two dark point with 2 pair maximum.  
 (e) )Line defect is defined as visible by using 5% ND filter.

Note:2 The external inspection should be conducted at the distance  $35 \pm 5$  cm between the eyes of inspctor and the panel .

Note:3 Luminance measurement for contrast ratio is at the distance  $50 \pm 5$  cm between the detective head and the panel with ambient illuminance less than 1 lux. Contrast ratio is obtained at optimum view angle.

Note:4 W-Width in mm , L-length of Max.(L1,L2) in mm.

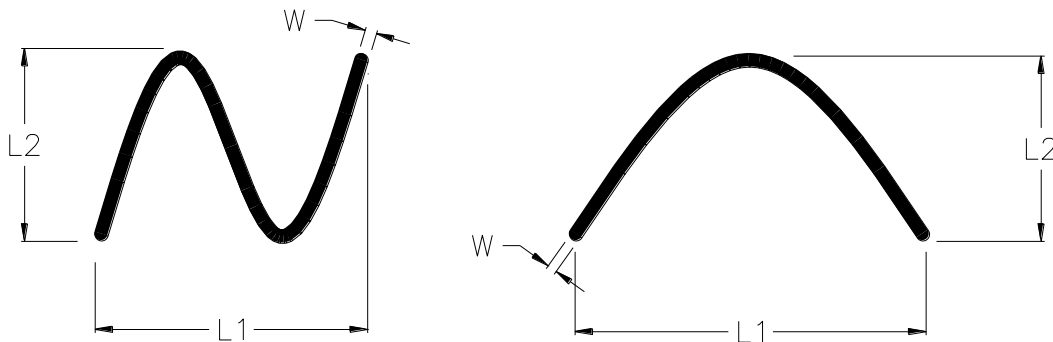

### 11.3 Sampling Condition

Unless otherwise agree in written, the sampling inspection shall be applied to the incoming inspection of customer.

Lot size: Quantity of shipment lot per model.

Sampling type: normal inspection, single sampling

Sampling table: MIL-STD-105E

Inspection level: Level II

## 12. LCM PRODUCT LABEL DEFINE

**Product Label style:**

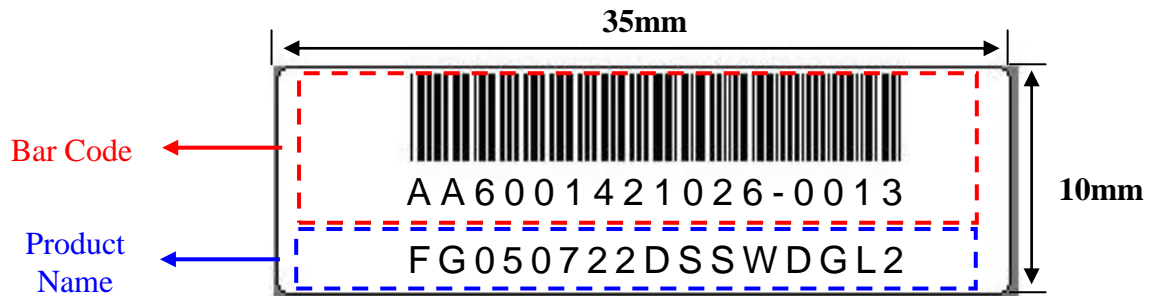

**Barcode Define:**

**A A 6 0014 2 10 26-0013**

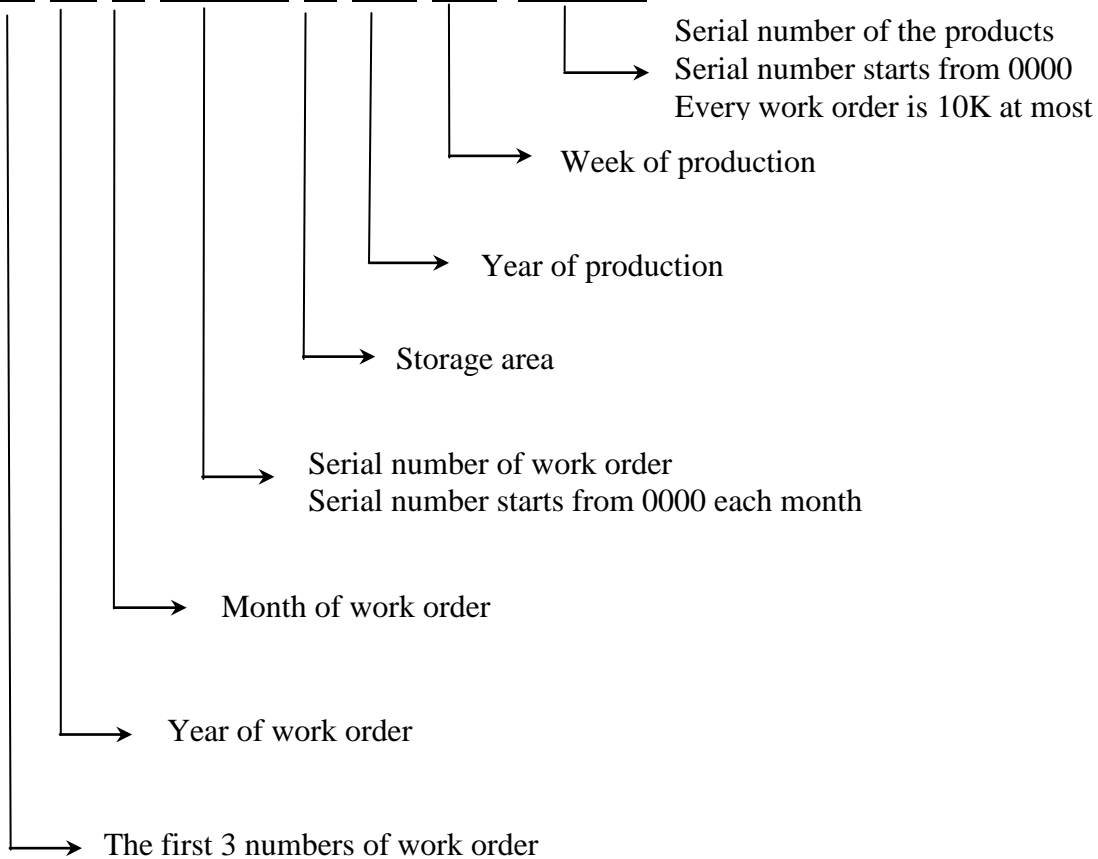

**Product Name Define:**

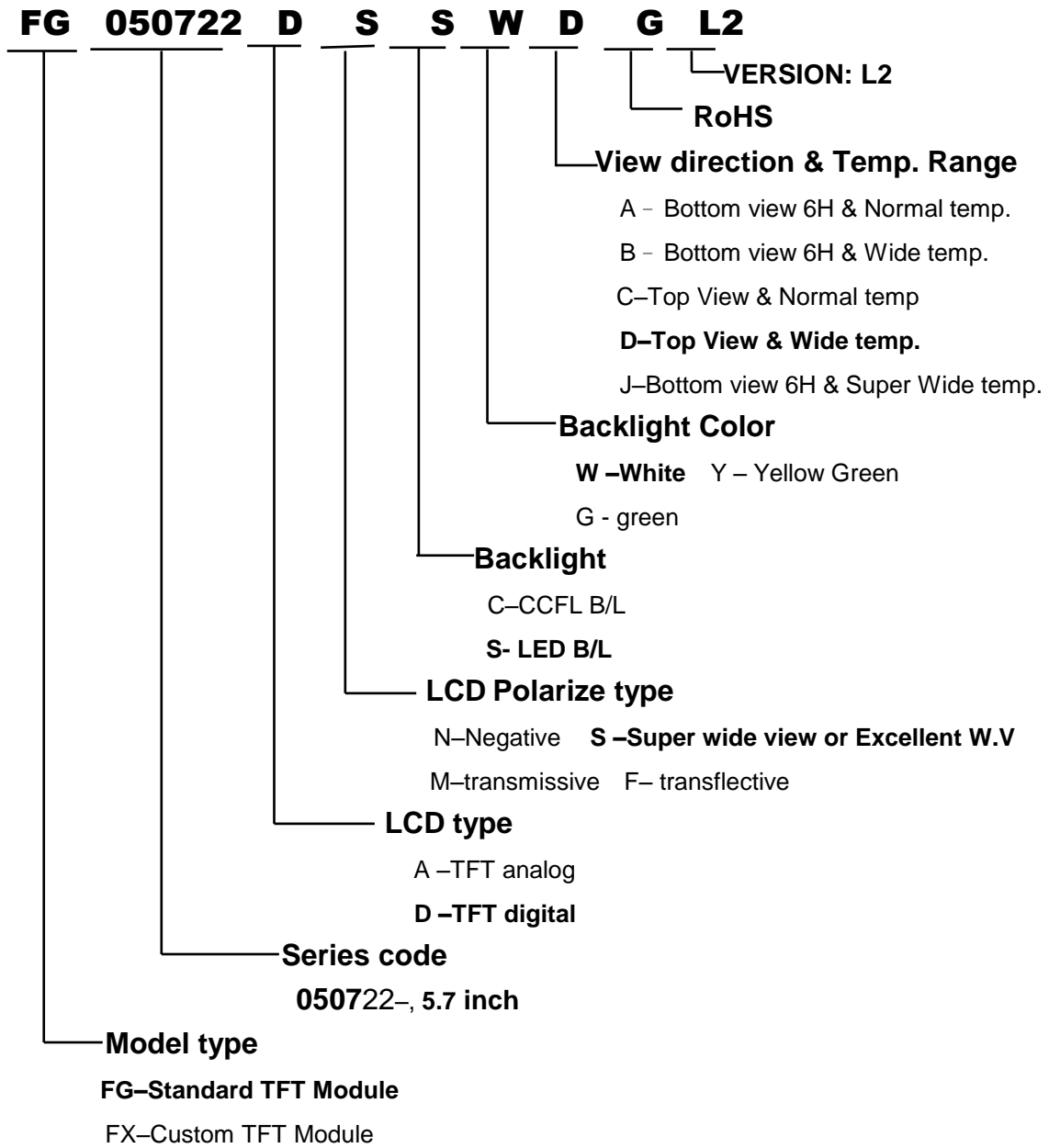

## 13. PRECAUTION IN USE LCM

### 1. ASSEMBLY PRECAUTIONS

- (1) You must mount a module using holes arranged in four corners or four sides.
- (2) You should consider the mounting structure so that uneven force (ex. Twisted stress) is not applied to the module. And the case on which a module is mounted should have sufficient strength so that external force is not transmitted directly to the module.
- (3) Do not touch, push or rub the exposed polarizers with glass, tweezers or anything harder than HB pencil lead. And please do not rub with dust clothes with chemical treatment.
- (4) Wipe off saliva or water drops as soon as possible. Their long time contact with polarizer causes deformations and color fading.
- (5) Do not open the case because inside circuits do not have sufficient strength.
- (6) Please do not take a LCD module to pieces and reconstruct it. Resolving and reconstructing modules may cause them not to work well.
- (7) Please do not touch metal frames with bare hands and soiled gloves. A color change of the metal frames can happen during a long preservation of soiled LCD modules.
- (8) Please pay attention to handling lead wire of backlight so that it is not tugged in connecting with inverter.

### 2. OPERATING PRECAUTIONS

- (1) Please be sure to turn off the power supply before connecting and disconnecting signal input cable.
- (2) Please do not change variable resistance settings in LCD module. They are adjusted to the most suitable value. If they are changed, it might happen LCD does not satisfy the characteristics specification
- (3) Be careful for condensation at sudden temperature change. Condensation makes damage to polarizer or electrical contacted parts. And after fading condensation, smear or spot will occur.
- (4) When fixed patterns are displayed for a long time, remnant image is likely to occur.
- (5) Module has high frequency circuits. Sufficient suppression to the electromagnetic interference shall be done by system manufacturers. Grounding and shielding methods may be important to minimize the interference.
- (6) Please consider that LCD backlight takes longer time to become stable of radiation characteristics in low temperature than in room temperature.

### 3. ELECTROSTATIC DISCHARGE CONTROL

- (1) The operator should be grounded whenever he/she comes into contact with the module. Never touch any of the conductive parts such the copper leads on the PCB and the interface terminals with any

parts of the human body.

- (2) The modules should be kept in antistatic bags or other containers resistant to static for storage.
- (3) Only properly grounded soldering irons should be used.
- (4) If an electric screwdriver is used, it should be well grounded and shielded from commutator sparks.
- (5) The normal static prevention measures should be observed for work clothes and working benches; for the latter conductive (rubber) mat is recommended
- (6) Since dry air is inductive to statics, a relative humidity of 50-60% is recommended.

### 4. STORAGE PRECAUTIONS

- (1) When you store LCDs for a long time, it is recommended to keep the temperature between 0°C-40°C without the exposure of sunlight and to keep the humidity less than 90%RH.
- (2) Please do not leave the LCDs in the environment of high humidity and high temperature such as 60°C 90%RH
- (3) Please do not leave the LCDs in the environment of low temperature; below -20°C.

### 5. OTHERS

- (1) A strong incident light into LCD panel might cause display characteristics' changing inferior because of polarizer film, color filter, and other materials becoming inferior. Please do not expose LCD module direct sunlight and strong UV rays
- (2) Please pay attention to a panel side of LCD module not to contact with other materials in preserving it alone.
- (3) For the packaging box, please pay attention to the followings:
- (4) Please do not pile them up more than 5 boxes. (They are not designed so.) And please do not turn over.
- (5) Please handle packaging box with care not to give them sudden shock and vibrations. And also please do not throw them up.
- (6) Packing box and inner case for LCDs are made of cardboard. So please pay attention not to get them wet. (Such like keeping them in high humidity or wet place can occur getting them wet.)

### 6. LIMITED WARRANTY

Unless otherwise agreed between DATA IMAGE and customer, DATA IMAGE will replace or repair any of its LCD and LCM which is found to be defective electrically and visually when inspected in accordance with DATA IMAGE acceptance standards, for a period on one year from date of shipment. Confirmation of such date shall be based on freight documents. The warranty liability of DATA IMAGE is limited to repair and/or replacement on the terms set forth above. DATA IMAGE will not responsible for any subsequent or consequential events.

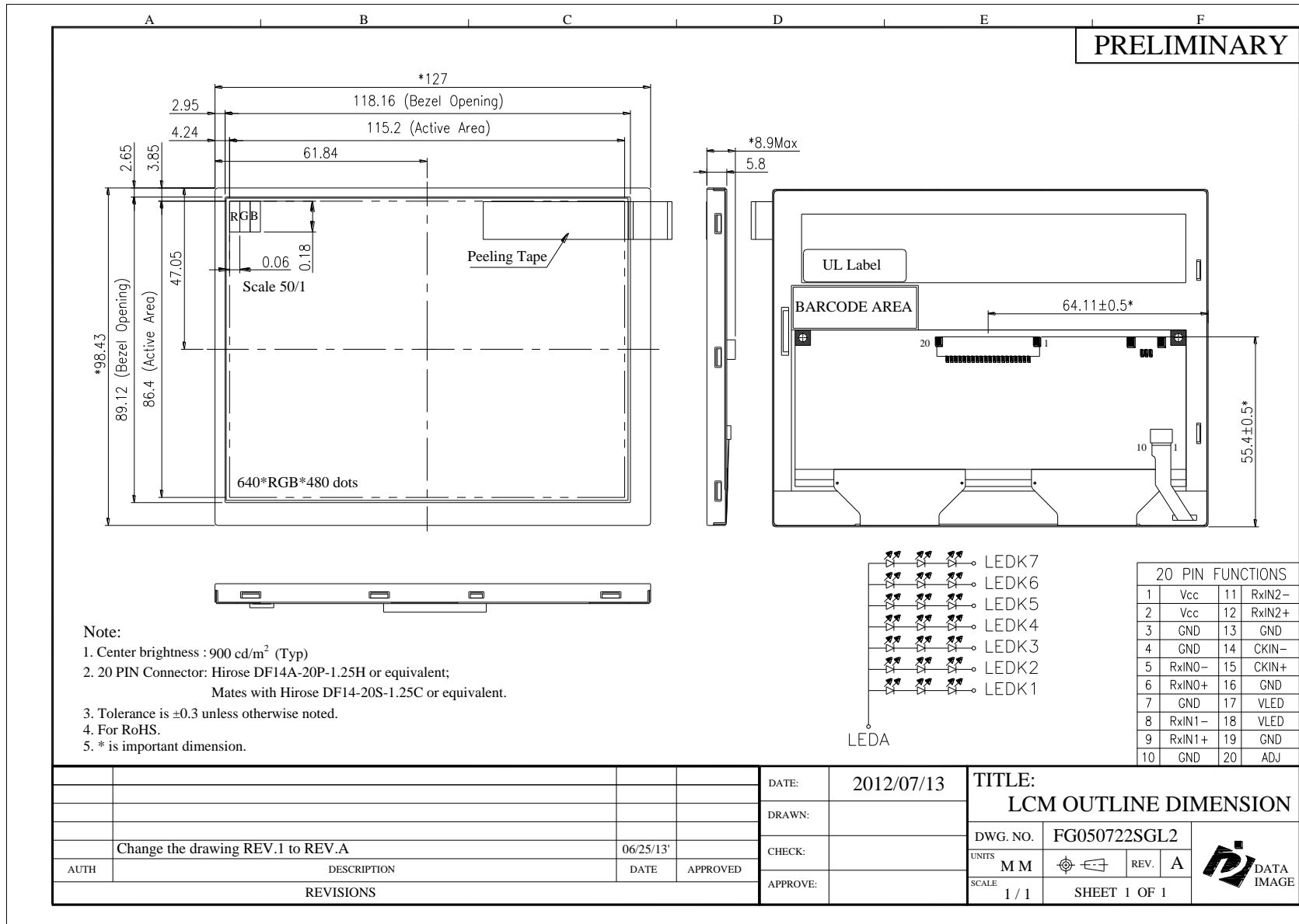
**14. OUTLINE DRAWING**

## 15. PACKAGE INFORMATION

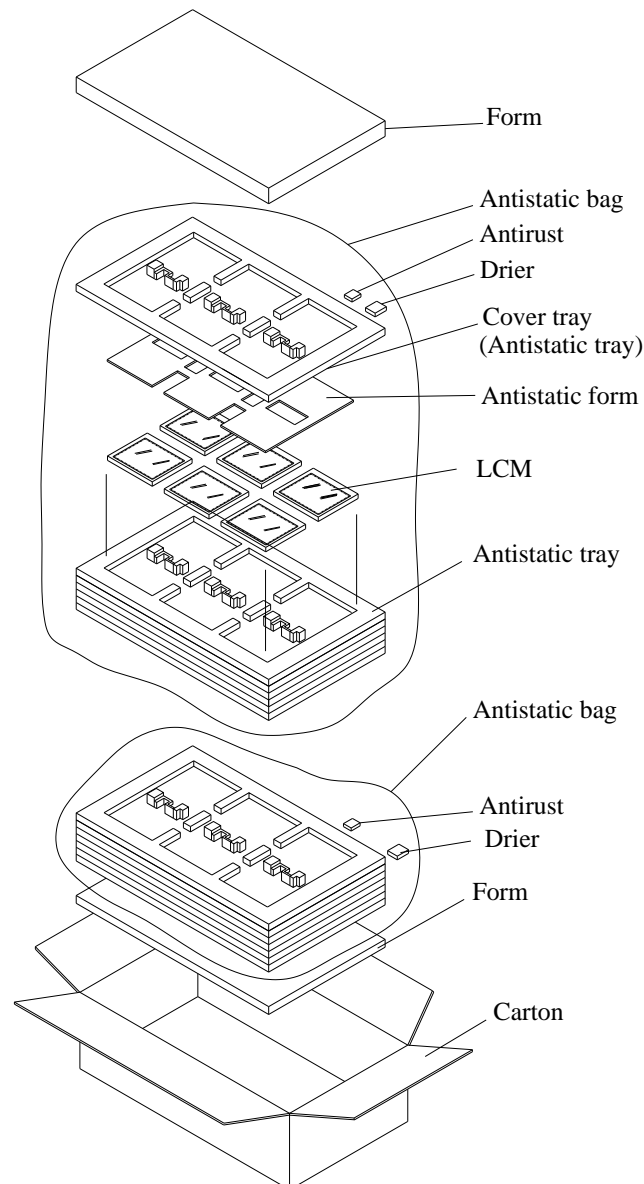

### Material

1 Carton + 2 Anti-static bag + 1 Form(35mm) + 1 Form(15mm)  
+ 14 Anti-static tray + 2 Drier + 2 Antirust

### Total pcs

1 Antistatic tray = 6 pcs

1 Anti-static bag = 6 Anti-static tray + cover tray =  $6*6 + 1*0 = 36$  pcs

1 Carton = 2 Anti-static bag =  $2*36 = 72$  pcs

1 Carton = 72pcs

Carton size : 482L x 282W x 279H (mm)

Total Weight  $\div$  11 kgw

**FG050722 TFT LCM PACKING**