

PRODUCT SPECIFICATION

20X2CHARACTERSLCD MODULE
MODEL: C2002A5SGW6B-F0 Ver:1.2
DRAWING VERSION: Ver: B

<◇> Preliminary Specification
<◆>Finally Specification

CUSTOMER'S APPROVAL	
CUSTOMER :	
SIGNATURE:	DATE:

APPROVED BY	PM REVIEWED	PD REVIEWED	PREPARED BY
	—		

Table of Contents

No.	Contents	Page
1.	FEATURES	4
2.	MECHANICAL SPECIFICATIONS	4
3.	ELECTRICAL SPECIFICATIONS	4
4.	TERMINAL FUNCTIONS AND BLOCK DIAGRAM	6
5.	TIMING CHARACTERISTICS	7
6.	COMMAND LIST	10
7.	CHARACTER GENERATOR ROM	11
8.	POLAROID	12
9.	QUALITY SPECIFICATIONS	13
10.	RELIABILITY	18
11.	HANDLING PRECAUTION	19
12.	OUTLINE DIMENSION	20

1. Features

The features of LCD are showed as follows

- * Display mode : STN-BLUE /Transmissive/Negative
- * Drive IC : UCi7066-01(English and Japanese)
- * Display format : 20*2Characters
- * Interface Input Data : 8 Bit or 4Bit MPU
- * Driving Method : 1/16Duty, 1/5 Bias
- * Viewing Direction : 6 O'clock
- * Backlight : 3 LED/Side White
- *Sample NO. :C2002A5SGW6B-F0-02/20220414

2. MECHANICAL SPECIFICATIONS

Item	Specification	Unit
Module Size	116(W) x 37(H) x 14MAX(D)	mm
Viewing Area	85(H) x 19.8(V)	mm
Activity Display Area	73.5(H) x 11.5(V)	mm
Character Font	5 x 8 Dots	-
Character Size	3.2(H) x 5.55(V)	mm
Character Pitch	3.7(H) x 5.95(V)	mm
Dot Size	0.6(H) x 0.65(V)	mm

3. ELECTRICAL SPECIFICATIONS

3-1 ABSOLUTE MAXIMUM RATINGS

Item	Symbol	Min	Max	Unit
Supply Voltage For Logic	$V_{DD} - V_{SS}$	-0.3	7.0	V
Supply Voltage For LCD Drive	$V_{OP} = V_{DD} - V_0$	$V_{DD} - 10$	$V_{DD} + 0.3$	V
Input Voltage	V_{in}	-0.3	$V_{DD} + 0.3$	V
Operating Temp.	T_{op}	-20	+70	°C
Storage Temp.	T_{st}	-30	+80	°C

*. NOTE: The response time will be extremely slow when the operating temperature is around -10°C , and the back ground will become darker at high temperature operating.

3-2 ELECTRICAL CHARACTERISTICS

Item	Symbol	Test Condition	Min.	Typ.	Max.	Unit	
Logic supply Voltage	$V_{DD} - V_{SS}$	$T_a = 25\text{ }^\circ\text{C}$ $V_{DD}=5.0V \pm 10\%$	4.5	5.0	5.5	V	
LCD Drive	$V_{OP}=V_{DD}-V_0$		4.2	4.4	4.6	V	
Input Voltage	"H" Level		V_{IH}	$0.7 V_{DD}$	-	V_{DD}	V
	"L" Level		V_{IL}	-0.3	-	0.6	V
Frame Frequency	f_{FLM}		-	78.1	-	Hz	
Current Consumption	I_{DD}		-	1.46	-	mA	

3-3BACKLIGHT

3-3-1. Absolute Maximum Ratings

Item	Symbol	Condition	Min.	Typ.	Max.	Unit
Forward Current	I_{fm}	$T_a = 25\text{ }^\circ\text{C}$	-	-	56	mA
Reverse Voltage	VR		-	-	5	V
Power Dissipation	PD		-	-	216	mW

3-3-2. Electrical-optical Characteristics

Item	Symbol	Condition	Min.	Typ.	Max.	Unit
Forward Current	I_F	$T_a = 25\text{ }^\circ\text{C}$ $V_f=4.8V$	-	36	45	mA
Average Luminous Intensity	L_v		300	400	-	cd/m ²
Color Coordinate	X		0.25	0.28	0.32	
	Y		0.25	0.28	0.32	

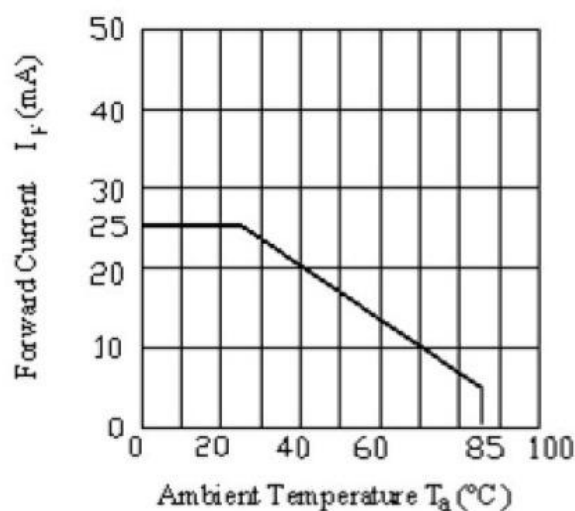

The brightness is measured without LCD panel

For operation above $25\text{ }^\circ\text{C}$, The I_{fm} & P_d must be derated, the current derating is $-0.36*3\text{mA}/^\circ\text{C}$ for DC drive and $-0.86*3\text{mA}/^\circ\text{C}$ for Pulse drive, the Power dissipation is $-0.75*3\text{mW}/^\circ\text{C}$. The product working current must not more than the 60% of the I_{fm} or I_{fp} according to the working temperature.

4. TERMINAL FUNCTIONS AND BLOCK DIAGRAM

4-1 INTERFACE PIN FUNCTION DESCRIPTION

PIN NO.	SYMBOL	FUNCTIONS
1	VSS	Ground
2	VDD	Supply voltage for logical circuit
3	V0	Supply voltage for LCD driving
4	RS	A signal for selecting registers. 1: Data Register (for read and write) 0: Instruction Register (for write)
5	WR	A signal for selecting read or write actions.1: Read, 0: Write.
6	E	A enable signal for reading or writing data.
7-14	DB0~DB7	8 Bit Data bus
15	LEDA	Backlight(+5.0V)
16	LEDK	Backlight(-)

4-2 BLOCK DIAGRAM

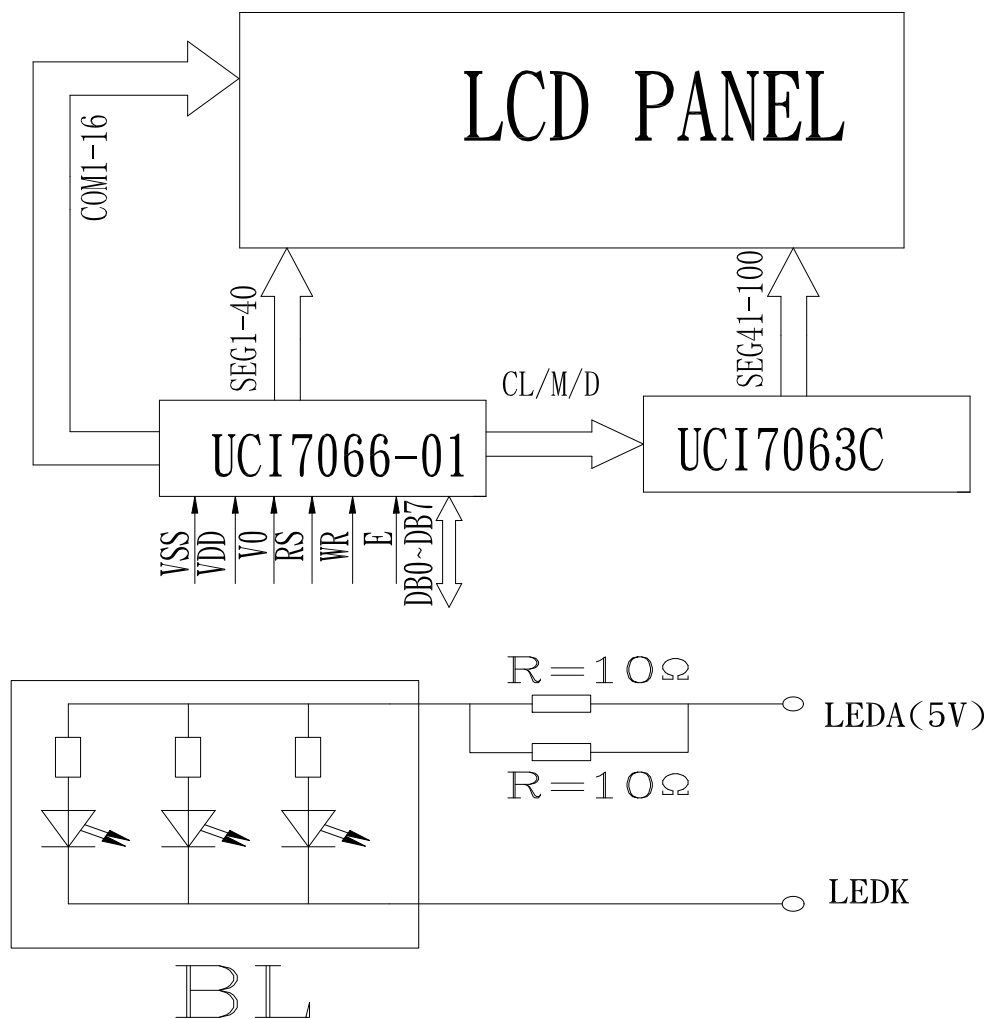

5. TIMING CHARACTERISTICS

5-1 Reading data from UCI7066U to MPU

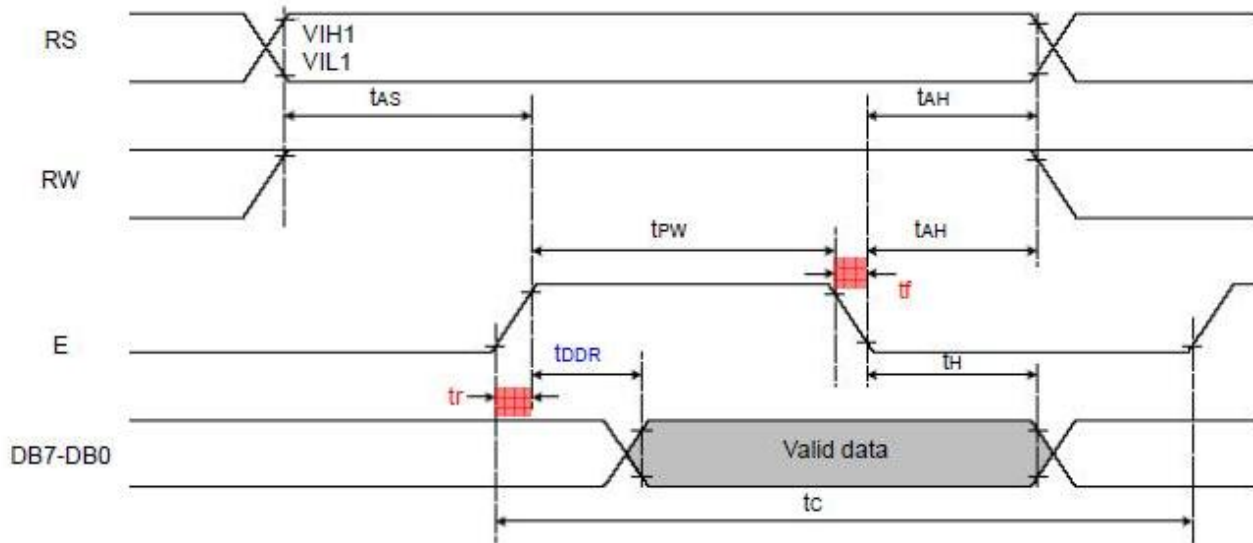

5-2 Writing data from MPU to UCI7066U

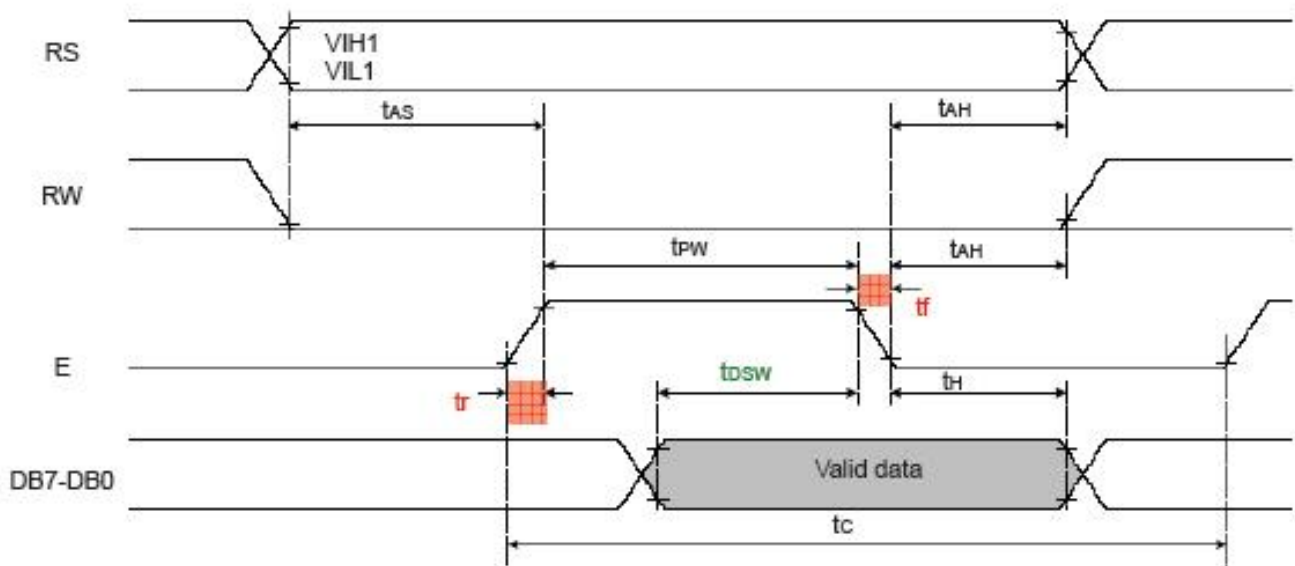

(6800 Write data to UCI7066c)

5-3 With External Driver

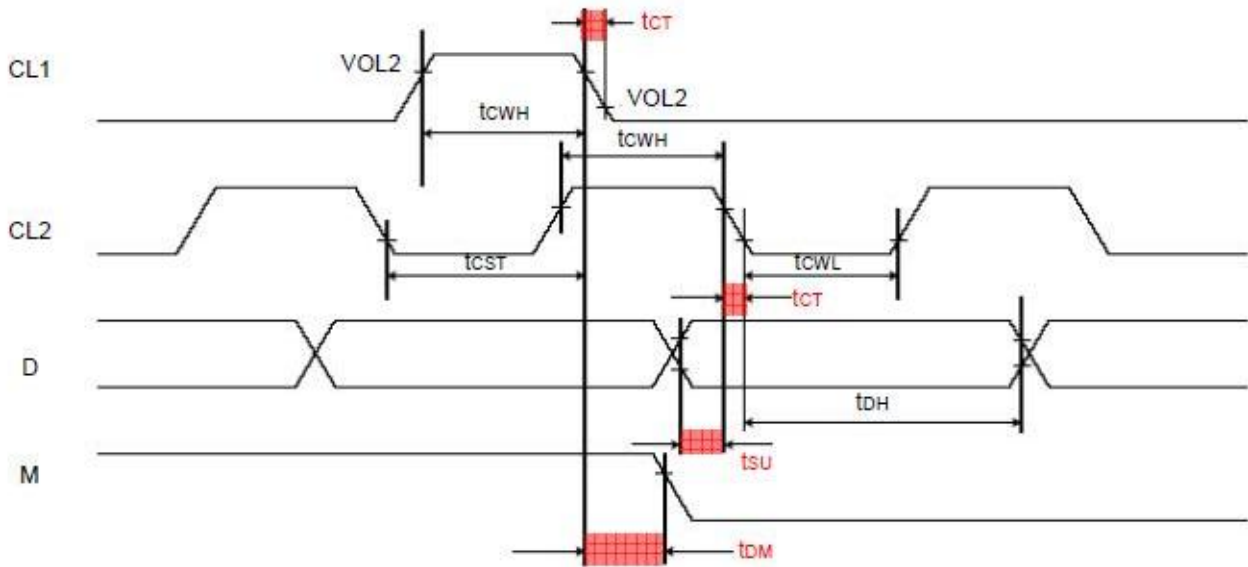

5-4 Power Supply Conditions

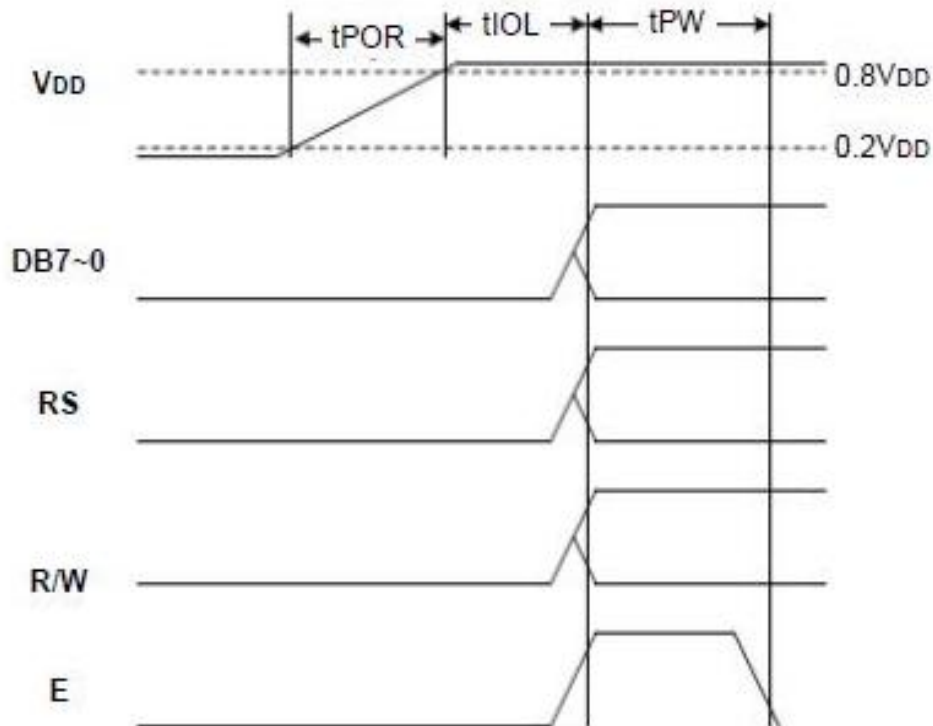

Symbol	Characteristics	Description	Min	Typ.	Max.	Unit
tPOR	Power Rise time	Power rise time that will trigger internal POR circuit	0.1		100	mS
tIOL	I/O Low time	The period that I/O is kept LOW	40			mS
tPW	Enable Pulse width	Please refer to the following tables				

5-5 Parameter

TA = 25°C, Vcc=4.5V~5V

Symbol	Characteristic	Test Condition	Min.	Typ.	Max.	Unit
Internal Clock Operation						
fosc	OSC Frequency	R=91KΩ	190	270	350	KHz
External Clock Operation						
fex	External Frequency	--	125	270	410	KHz
	Duty Cycle	--	45	50	55	%
tr, tf	Rising/Falling Time	--	--	--	0.2	μs
Write Mode (MPU writes data to UCi7066)						
tc	Enable Cycle Time	Pin E	1200	--	--	nS
tpw	Enable Pulse Width	Pin E	140	--	--	nS
tr, tf	Rising/Falling Time	Pin E	--	--	25	nS
tas	Address Setup Time	Pin: RS, RW, E	0	--	--	nS
tah	Address Hold Time	Pin: RS, RW, E	10	--	--	nS
t _{DSW}	Data Setup Time	Pin: DB7~DB0	40	--	--	nS
th	Data Hold Time	Pin: DB7~DB0	10	--	--	nS
Read Mode (MPU reads data from UCi7066)						
tc	Enable Cycle Time	Pin E	1200	--	--	nS
tpw	Enable Pulse Width	Pin E	140	--	--	nS
tr, tf	Rising/Falling Time	Pin E	--	--	25	nS
tas	Address Setup Time	Pin: RS, RW, E	0	--	--	nS
tah	Address Hold Time	Pin: RS, RW, E	10	--	--	nS
t _{DDR}	Data Setup Time	Pin: DB7~DB0	--	--	100	nS
th	Data Hold Time	Pin: DB7~DB0	10	--	--	nS
Interface Mode with LCD Driver (UCi7065)						
tc _{WH}	Clock Pulse Width, High	Pin: CL1, CL2	800	--	--	nS
tc _{WL}	Clock Pulse Width, Low	Pin: CL1, CL2	800	--	--	nS
tc _{ST}	Clock Setup Time	Pin: CL1, CL2	500	--	--	nS
tsu	Data Setup Time	Pin: D	300	--	--	nS
t _{DH}	Data Hold Time	Pin: D	300	--	--	nS
t _{DM}	M Delay Time	Pin: M	0	--	2000	nS

623+6.COMMAND LIST

The following is a list of host commands supported by UCi7066

R/S: 0: Control, 1: Data

W/R: 0: Write Cycle, 1: Read Cycle

D7-D0: -: Don't Care

#	Command	RS	R/W	D7	D6	D5	D4	D3	D2	D1	D0	Action
1	Clear Display	0	0	0	0	0	0	0	0	0	1	Clear the screen
2	Return Home	0	0	0	0	0	0	0	0	1	-	Move cursor to HOME
3	Set Entry Mode	0	0	0	0	0	0	0	1	I/D	S	I/D: Left / Right S: Shift OFF/ON
4	Display ON/OFF	0	0	0	0	0	0	1	D	C	B	D: Display OFF / ON C: Cursor OFF / ON B: Blink OFF / ON
5	Cursor or Display Shift	0	0	0	0	0	1	S/C	R/L	-	-	S/C: Screen / Cursor R/L Right / Left
6	Set Function	0	0	0	0	1	DL	N	F	-	-	DL: 4-bit / 8-bit, N: 1-line / 2-line F: 5x8 / 5x11
7	Set CGRAM address	0	0	0	1	AC5	AC4	AC3	AC2	AC1	AC0	
8	Set DDRAM address	0	0	1	AC12	AC11	AC10	AC9	AC8	AC7	AC6	
9	Read Busy Flag and address	0	1	BF	AC19	AC18	AC17	AC16	AC15	AC14	AC13	
10	Write data to RAM	1	0	D7	D6	D5	D4	D3	D2	D1	D0	Write data to RAM
11	Read data from RAM	1	1	D7	D6	D5	D4	D3	D2	D1	D0	Read data from RAM
For S8/S9 Mode												
12	Status Read	1	1	0	0	0	0	0	0	0	0	Read status
		0	1	BF	AC19	AC18	AC17	AC16	AC15	AC14	AC13	

Note:

Ensure that UCi7066 is not in the BUSY state (BF = 0) before sending an instruction from the MPU to the UCi7066. If an instruction is sent without checking the busy flag, the time between the first instruction and next instruction will take much longer than the instruction time itself.

7.CHARACTER GENERATOR ROM

Correspondence between Character Codes and Character Patterns (ROM Code: 0A)

No. 7066-01

Upper 4 bits Lower 4 bits	0000	0001	0010	0011	0100	0101	0110	0111	1000	1001	1010	1011	1100	1101	1110	1111
0000				0	1	2	3	4					5	6	7	8
0001			!	1	2	3	4	5			.	6	7	8	9	0
0010			"	2	3	4	5	6			'	7	8	9	0	1
0011			#	3	4	5	6	7			，	8	9	0	1	2
0100			\$	4	5	6	7	8			、	9	0	1	2	3
0101			%	5	6	7	8	9			。	0	1	2	3	4
0110			&	6	7	8	9	0			、	1	2	3	4	5
0111			'	7	8	9	0	1			、	2	3	4	5	6
1000			(8	9	0	1	2			、	3	4	5	6	7
1001)	9	0	1	2	3			、	4	5	6	7	8
1010			*	0	1	2	3	4			、	5	6	7	8	9
1011			+	1	2	3	4	5			、	6	7	8	9	0
1100			,	2	3	4	5	6			、	7	8	9	0	1
1101			-	3	4	5	6	7			、	8	9	0	1	2
1110			.	4	5	6	7	8			、	9	0	1	2	3
1111			/	5	6	7	8	9			、	0	1	2	3	4

8. Polaroid

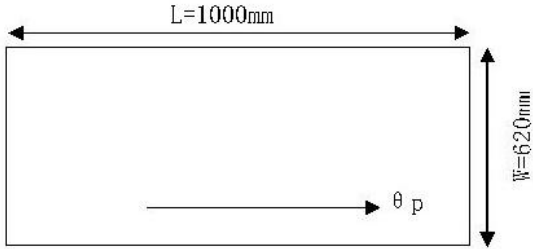
Part no		HN1822MA															
structure		size															
<table border="1"> <tr><td>1</td><td>Release film</td></tr> <tr><td>2</td><td>Sticker</td></tr> <tr><td>3</td><td>TAC</td></tr> <tr><td>4</td><td>PVA</td></tr> <tr><td>5</td><td>TAC</td></tr> <tr><td>6</td><td>Sticker</td></tr> <tr><td>7</td><td>Reflective Film</td></tr> </table>		1	Release film	2	Sticker	3	TAC	4	PVA	5	TAC	6	Sticker	7	Reflective Film	 <p>*release film upwards; θ_p = Polaroid absorb the shaft</p>	
1	Release film																
2	Sticker																
3	TAC																
4	PVA																
5	TAC																
6	Sticker																
7	Reflective Film																

item		unit	spec value	notes
size	length	mm	1000(±10)	
	width	mm	620(±10)	
thickness	effective thickness	μm	280±10%	
	Release film	μm	38±10%	
Strip Force	To glasses	gf/25mm	Above 500g	
	Release film	gf/25mm	Under 20g	
Transmittance	Monomer transmittance	%	42.0±1.5	The original panel data
	Rectangular transmittance	%	≤2.0	The original panel data
	380nm transmittance	%	≤1.0	
Angle	Cutting Angle	°	90±1.0	
	Absorption of shaft Angle	°	±2.0	
BENDING		mm	≤±50	
Hue	L	NBS	65.0±2.0	The original panel data
	a	NBS	-1.97±2.0	The original panel data
	b	NBS	2.98±2.0	The original panel data
degree of polarization		%	≥99.0	The original panel data
apparent defect (above Diameter 150μm)			≤13/pcs	
80°C*500Hr	(post-testing)Transmittance≥99.0%			
60°C*90%RH*500Hr	Monomer transmittance change value≤3.0%			
	Hue change value≤3.0 No separation, no foam, stripping (within edge 0.5mm)			

9. QUALITY SPECIFICATIONS

9-1. LCM Appearance and Electric inspection Condition

1. Inspection will be done by placing LCM 30cm away from inspector's eyeballs under normal illumination.

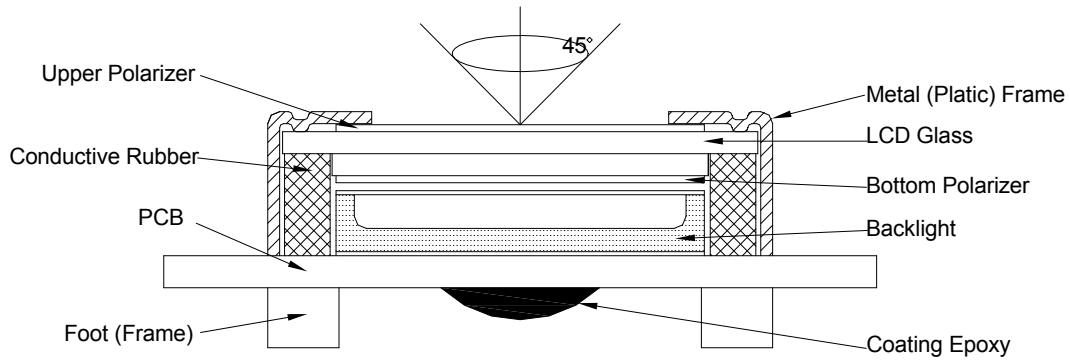

2. View Angle: with in 45° around perpendicular line.

9-2. Definition

1. COB

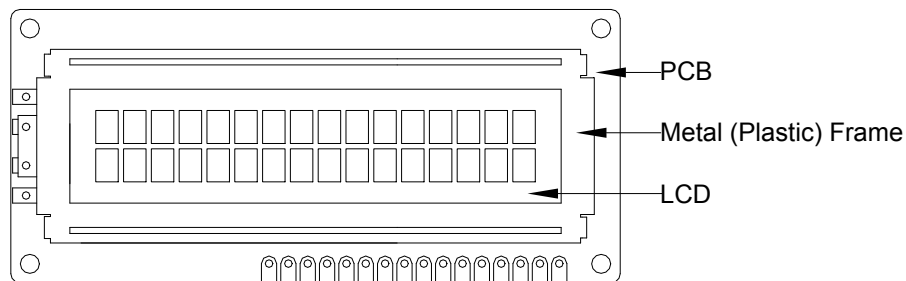

2. Heat Seal

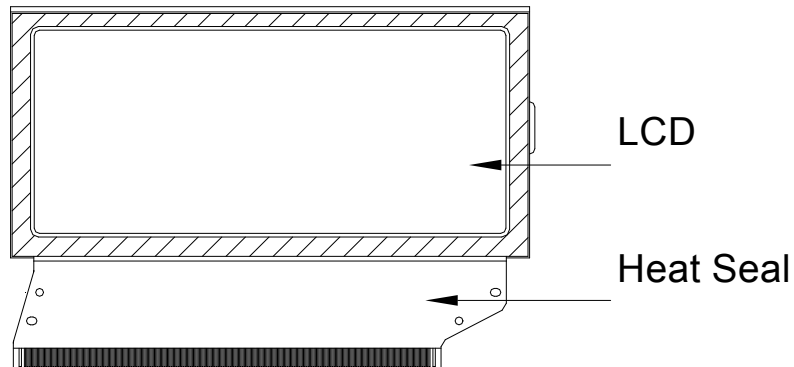

3. TAB and COG

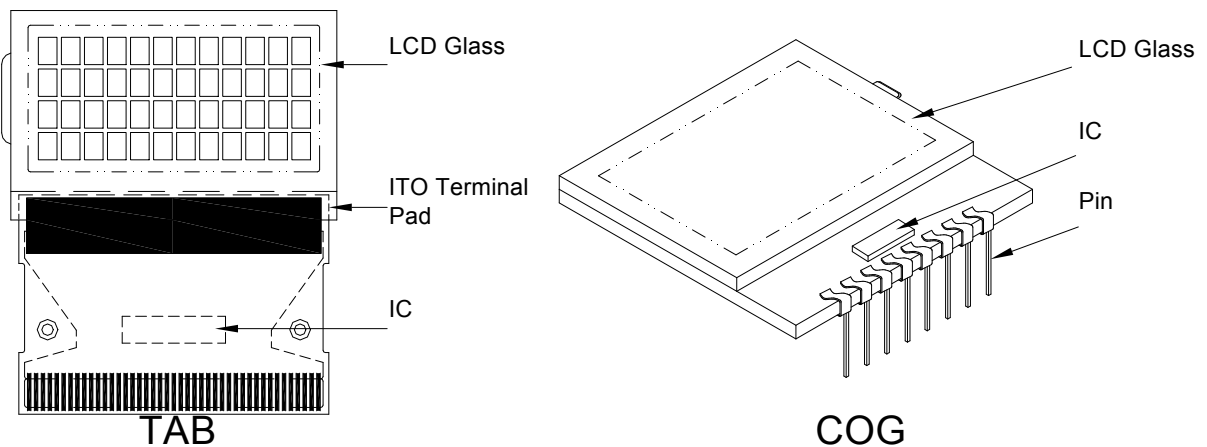

9-3. Sampling Plan and Acceptance

1. Sampling Plan

MIL - STD - 105E (||) ordinary single inspection is used.

2. Acceptance

Major defect: AQL = 0.65%

Minor defect: AQL = 1.5%

9-4. Criteria

1. COB

Defect	Inspection Item	Inspection Standards	
Major	PCB copper flakes peeling off	Any copper flake in viewing Area should be greater than 1.0mm ²	Reject
Major	Height of coating epoxy	Exceed the dimension of drawing	Reject
Major	Void or hole of coating epoxy	Expose bonding wire or IC	Reject
Major	PCB cutting defect	Exceed the dimension of drawing	Reject

2. SMT

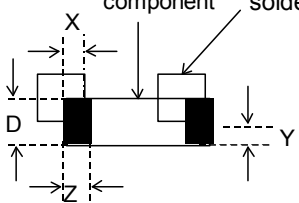
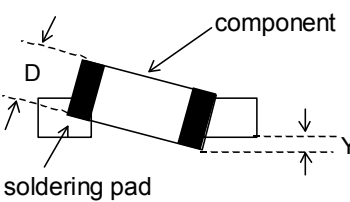
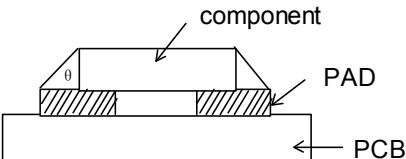
Defect	Inspection Item	Inspection Standards	
Minor	Component marking not readable		Reject
Minor	Component height	Exceed the dimension Of drawing	Reject
Major	Component solder defect (missing , extra, wrong component or wrong orientation)		Reject
Minor	Component position shift 	$X < 3/4Z$ $Y > 1/3D$	Reject Reject
Minor	Component tilt 	$Y > 1/3D$	Reject
Minor	Insufficient solder 	$\theta \leq 20^\circ$	Reject

3. Metal (Plastic) Frame

Defect	Inspection Item	Inspection Standards	
Major	Crack / breakage	Anywhere	
Minor	Frame Scratch	W	L
		$w < 0.1\text{mm}$	Any
		$0.1 \leq w < 0.2\text{mm}$	$L \leq 5.0\text{mm}$
		$0.2 \leq w < 0.3\text{mm}$	$L \leq 3.0\text{mm}$
		$w \geq 0.3\text{mm}$	Any
		Note : 1. Above criteria applicable to scratch lines with distance greater than 5mm. 2. Scratch on the back side of frame (not visible) can be ignored .	
Minor	Frame Dent , Prick $\Phi = \frac{L + W}{2}$		Acceptable of Dents / Pricks
		$\Phi \leq 1.0\text{mm}$	2
		$1.0 < \Phi \leq 1.5\text{mm}$	1
		$1.5\text{mm} < \Phi$	0
Note : 1. Above criteria applicable to any two dents / pricks with distance greater than 5mm 2. Dent / prick on the back side of frame (not visible) can be ignored			
Minor	Frame Deformation	Exceed the dimension of drawing	
Minor	Metal Frame Oxidation	Any rust	

4. Flexible Film Connector (FFC)

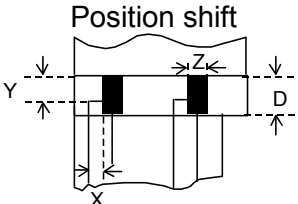
Defect	Inspection Item	Inspection Standards	
Minor	Tilted soldering	Within the angle $+5^\circ$	Acceptable
Minor	Uneven solder joint /bump		Reject
Minor	Hole $\Phi = \frac{L + W}{2}$	Expose the conductive line	Reject
		$\Phi > 1.0\text{mm}$	Reject
Minor		$Y > 1/3D$	Reject
		$X > 1/2Z$	Reject

5. Screw

Defect	Inspection Item	Inspection Standards	
Major	Screw missing/loosen		Reject
Minor	Screw oxidation	Any rust	Reject
Minor	Screw deformation	Difficult to accept screw driver	Reject

6. Heatseal 、TCP 、FPC

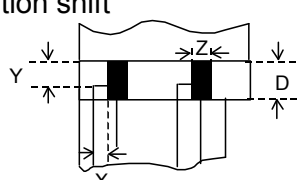
Defect	Inspection Item	Inspection Standards	
Major	Scratch expose conductive layer		Reject
Minor	HS Hole $\Phi = \frac{L+W}{2}$	$\Phi > 0.5\text{mm}$	Reject
Major	Adhesion strength	Less than the specification	Reject
Minor	Position shift 	$Y > 1/3D$	Reject
		$X > 1/2Z$	Reject
Major	Conductive line break		Reject

7. LED Backing Protective Film and Others

Defect	Inspection Item	Inspection Standards	
Minor	LED dirty, prick	Acceptable number of units	
		$\Phi \leq 0.10\text{mm}$	Ignore
		$0.10 < \Phi \leq 0.15\text{mm}$	2
		$0.15 < \Phi \leq 0.2\text{mm}$	1
		$\Phi > 0.2\text{mm}$	0
The distance between any two spots should be $\geq 5\text{mm}$ Any spot/dot/void outside of viewing area is acceptable			
Minor	Protective film tilt	Not fully cover LCD	Reject
Major	COG coating	Not fully cover ITO circuit	Reject

8. Electric Inspection

Defect	Inspection Item	Inspection Standards	
Major	Short		Reject
Major	Open		Reject

9. Inspection Specification of LCD

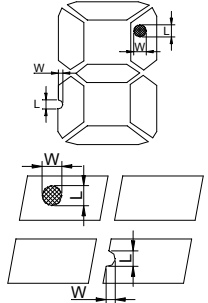
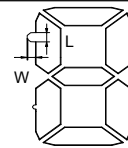
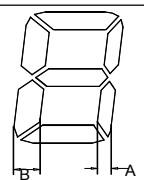
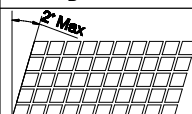
Defect	Inspect Item	Inspection Standards				
Minor	Linear Defect * Glass Scratch * Polarizer Scratch * Fiber and Linear material	W	$W \leq 0.03$	$0.03 < W \leq 0.05$	$W > 0.05$	
		L	$L < 5$	$L < 3$	Any	
		ACC. NO.	1	1	Reject	
		Note	L is the length and W is the width of the defect			
Minor	Black Spot and Polarizer Pricked * Foreign material between glass and polarizer or glass and glass * Polarizer hole or protuberance by external force	Φ	$\Phi \leq 0.1$	$0.1 < \Phi \leq 0.15$	$0.15 < \Phi \leq 0.2$	$\Phi > 0.2$
		ACC. NO.	3EA / 100mm ²	2	1	0
		Note	Φ is the average diameter of the defect. Distance between two defects >10mm.			
Minor	White Spot and Bubble in polarizer * Unobvious transparent foreign material between glass and glass or glass and polarizer * Air protuberance between polarizer and glass	Φ	$\Phi \leq 0.3$	$0.3 < \Phi \leq 0.5$	$0.5 < \Phi$	
		ACC. NO.	3EA / 100mm ²	1	0	
		Note	Φ is the average diameter of the defect. Distance between two defects >10mm.			
Minor	Segment Defect 	Φ	$\Phi \leq 0.10$	$0.10 < \Phi \leq 0.20$	$0.20 < \Phi \leq 0.25$	$\Phi > 0.25$
		ACC. NO.	3EA / 100mm ²	2	1	0
		Note	W is more than 1/2 segment width			Reject
		Note	$\Phi = \frac{L + W}{2}$ Distance between two defect is 10mm			
Minor	Protuberant Segment  $\Phi = (L + W) / 2$	Φ	$\Phi \leq 0.10$	$0.10 < \Phi \leq 0.20$	$0.20 < \Phi \leq 0.25$	$\Phi > 0.25$
		W	Glue	$W \leq 1/2$ Seg $W \leq 0.2$	$W \leq 1/2$ Seg $W \leq 0.2$	Ignore
		ACC. NO.	3EA / 100mm ²	2	1	0
Minor	Assembly Mis-alignment  	1. Segment				
		B	$B \leq 0.4\text{mm}$	$0.4 < B \leq 1.0\text{mm}$	$B > 1.0\text{mm}$	
		B-A	$B-A < 1/2B$	$B-A < 0.2$	$B-A < 0.25$	
		Judge	Acceptable	Acceptable	Acceptable	
		2. Dot Matrix				
Deformation > 2°				Reject		
Minor	Stain on LCD Panel Surface	Accept when stains can be wiped lightly with a soft cloth or a similar one. Otherwise, judged according to the above items: "Black spot" and "White Spot"				

10. RELIABILITY

No	Item	Condition	Quantity	Criteria
1	High Temperature Operating	70°C, 96Hrs	2	GB/T2423.2-2008
2	Low Temperature Operating	-20°C, 96Hrs	2	GB/T2423.1-2008
3	High Humidity	60°C, 90%RH, 96Hrs	2	GB/T2423.3-2016
4	High Temperature Storage	80°C, 96Hrs	2	GB/T2423.2-2008
5	Low Temperature Storage	-30°C, 96Hrs	2	GB/T2423.1-2008
6	Thermal Cycling Test	-20°C, 60min~60°C, 60min, 20 cycles.	2	GB/T2423.22-2012
7	Packing vibration	Frequency range:10Hz~50Hz Acceleration of gravity:5G X,Y,Z 30 min for each direction.	2	GB/T5170.14-2009
8	Electrical Static Discharge	Air: ±8KV 150pF/330 Ω 5 times	2	GB/T17626.2-2018
		Contact: ±4KV 150pF/330 Ω 5 times		
9	Drop Test (Packaged)	Height:80 cm,1 corner, 3 edges, 6 surfaces.	2	GB/T2423.8-1995

Note:1) Above conditions are suitable for our company standard products.

2) For restrict products, the test conditions listed as above must be revised.

11. HANDLING PRECAUTION

(1) Mounting Method

The panel of the LCD Module consists of two thin glass plates with polarizers which easily get damaged since the Module is fixed by utilizing fitting holes in the printed circuit board. Extreme care should be taken when handling the LCD Modules.

(2) Caution of LCD handling & cleaning

When cleaning the display surface, use soft cloth with solvent (recommended below) and wipe lightly.

- Isopropyl alcohol
- Ethyl alcohol
- Trichlorotrifluoro ethane

Do not wipe the display surface with dry or hard materials that will damage the polarizer surface.

Do not use the following solvent:

- Water
- Ketone
- Aromatics

(3) Caution against static charge

The LCD Module use C-MOS LSI drivers, so we recommend that you connect any unused input terminal to VDD or VSS, do not input any signals before power is turned on. Ground your body, Work/assembly table. And assembly equipment to protect against static electricity.

(4) Packaging

- Modules use LCD elements, and must be treated as such. Avoid intense shock and falls from a height.
- To prevent modules from degradation. Do not operate or store them exposed directly to sunshine or high temperature/humidity.

(5) Caution for operation

- It is indispensable to drive LCD's within the specified voltage limit since the higher voltage than the limit shorten LCD life. An electrochemical reaction due to direct current causes LCD deterioration, Avoid the use of direct current drive.
- Response time will be extremely delayed at lower temperature than the operating temperature range and on the other hand at higher temperature LCD's show dark color in them. However those phenomena do not mean malfunction or out of order with LCD's. Which will come back in the specified operating temperature range.
- If the display area is pushed hard during operation, some font will be abnormally displayed but it resumes normal condition after turning off once.
- A slight dew depositing on terminals is a cause for electro-chemical reaction resulting in terminal open circuit.

Usage under the relative condition of 40 C, 50%RH or less is required.

(6) Storage

In the case of storing for a long period of time (for instance.) For years) for the purpose or replacement use, The following ways are recommended.

- Storage in a polyethylene bag with sealed so as not to enter fresh air outside in it, And with no desiccant.
- Placing in a dark place where neither exposure to direct sunlight nor light is. Keeping temperature in the specified storage temperature range.
- Storing with no touch on polarizer surface by anything else. (It is recommended to store them as they have been contained in the inner container at the time of delivery)

(7) Safety

- It is recommendable to crash damaged or unnecessary LCD into pieces and wash off liquid crystal by using solvents such as acetone and ethanol. Which should be burned up later.

When any liquid crystal leaked out of a damaged glass cell comes in contact with your hands, please wash it off well with soap and water.

(8) Other

- After the product shipped, any product quality issues must be feedback within three months, otherwise, we will not be responsible for the subsequent or consequential events.

12. OUTLINE DIMENSION

NOTE :The dimension with"()" is reference

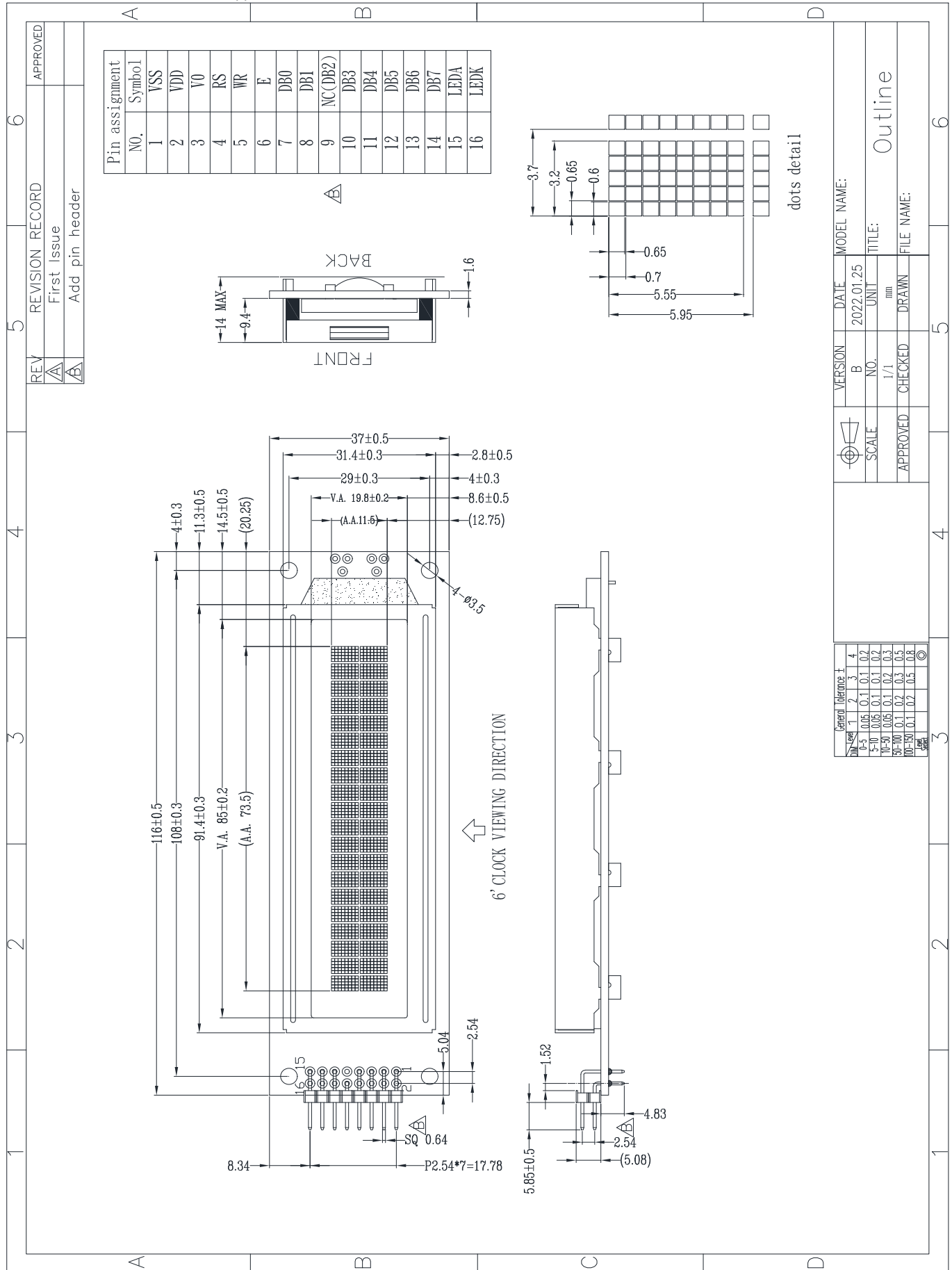

REV	REVISION RECORD	DATE	MODEL NAME:
A	First Issue	2022.01.25	
B	Add pin header		
SCALE	NO.	UNIT	TITLE:
	1/1	mm	Outline
APPROVED	CHECKED	DRAWN	FILE NAME:

General Tolerance	1	2	3	4
0.5	0.05	0.1	0.1	0.2
5.0	0.05	0.1	0.1	0.2
10.0	0.05	0.1	0.2	0.3
30.0	0.1	0.2	0.3	0.5
100.0	0.1	0.2	0.5	0.8